

Robin Industrial Engines®

SERVICE MANUAL

Model

EC12

OIL MIX & OIL INJECTION ENGINES

PUB-ES1173
Rev. 8/98

Robin
SUBARU

CONTENTS

<i>Section</i>	<i>Title</i>	<i>Page</i>
1.	SPECIFICATIONS	1
2.	PERFORMANCE	2
2-1	Maximum Output	2
2-2	Continuous Output	2
2-3	Maximum Torque	2
2-4	Performance Curves	3
3.	FEATURES	4
4.	GENERAL DESCRIPTIONS OF ENGINE COMPONENTS	4
4-1	Aluminum Cylinder and Crankcase	4
4-2	Cylinder Head	5
4-3	Crankshaft and Connecting Rod	5
4-4	Piston and Piston rings	5
4-5	All Speed Governor	6
4-6	Cooling System	6
4-7	Carburetor	6
4-8	Air Cleaner	7
4-9	Ignition System	7
4-10	Oil Injection System	7
4-11	Sectional View of Engine	8
5.	DISASSEMBLY	12
5-1	Preparation and Suggestions	12
5-2	Special Tool	12
5-3	Disassembly Procedures	13
6.	REASSEMBLY	22
6-1	Cleaning Before Reassembly	22
6-2	Checks and Corrections Before Reassembly	22
6-3	Precautions for Reassembly	22
6-4	Reassembly Procedures	23
6-5	Break-in Operation	32
7.	GOVERNOR	33
7-1	Construction and Operation	33
7-2	Governor Adjustment	34
7-3	High Speed Adjustment	34
8.	MAGNETO	36
8-1	Operation of the Ignition System	37
8-2	Ignition System Check	37
9.	CARBURETOR	38
9-1	Float Carburetor	38
9-2	Diaphragm Carburetor	41

10. OIL INJECTION SYSTEM	45
10-1 Separate oil injection/ fuel system	45
10-2 Basic structure of the separate oil injection/ fuel system	45
10-3 Oil pump operation/ function	46
11. RECOIL STARTER	50
11-1 Disassembly	50
11-2 Reassembly	51
11-3 Check After Reassembly	52
11-4 When Power Spring Escapes from Housing	52
12. TROUBLESHOOTING	53
12-1 Starting Difficulties	53
12-2 Slow-Speed Out of Order	54
12-3 Overheating and Knocking	54
12-4 Power Droop	54
12-5 Excessive Fuel Consumption	54
13. INSTALLATION	55
13-1 Installing	55
13-2 Ventilation	55
13-3 Exhaust Gas Discharge	55
13-4 Power Transmission to Drive Machines	56
13-5 Fuel System	56
14. CHECKS AND CORRECTIONS	57
14-1 Correction Table	58
14-2 Torque Specifications	60
15. MAINTENANCE AND STORING	61
15-1 Daily Maintenance	61
15-2 Every 50 Hours (10 Days) Maintenance	61
15-3 Every 100 to 200 Hours (Monthly) Maintenance	61
15-4 Every 500 to 600 Hours (Semiannual) Maintenance	61
15-5 Every 1000 Hours (Yearly) Maintenance	62
15-6 Preparation for Long Storage	62

1. SPECIFICATIONS

MODEL		EC12D STD.	EC12D OIL INJECTION SYSTEM
Type		Air-Cooled, 2-Cycle, 1-Cylinder, Gasoline-Engine	
Number of cylinder, Bore x Stroke		1 – 54 × 50 mm (2.13 × 1.97 in)	
Piston Displacement		114cc (6.98 cu.in)	
Horsepower	Continuous	2.2 kW (3.0 HP) / 3600 rpm	
	Max.	2.9 kW (4.0 HP) / 4000 rpm	
Max. Torque		7.5 / N-m (0.76 kg-m) / 3000 rpm	
Direction of Rotation		Counterclockwise as viewed from PTO Shaft	
Fuel		Automobile Gasoline (Mixed with Oil. Mixing Ratio 25 to 50:1)	Automobile Gasoline
Fuel Consumption		360 g / HP. hr @ 3.0 HP/ 3600 rpm	
Lubricant oil		2-Cycle Engine Oil	
Lubrication		Gasoline Oil Mixing Type (Mixing Ratio 25 to 50:1)	Oil separate fueling system
Carburetor		Float Type	
Method of ignition		Flywheel Magneto Type (Solid State Ignition)	
Spark Plug		NGK BM6A / CHAMPION CJ8	
Starting System		Recoil Starter	
Governor		Centrifugal Flyweight Type	
Air Cleaner		Semi-Wet Type	
Dry Weight		12.0 kg (26.0 lbs)	
Dimensions	Length	273 mm (10.7 in.)	
	Width	326 mm (12.8 in.)	
	Height	307 mm (12.1 in.)	

2. PERFORMANCE

2-1 MAXIMUM OUTPUT

The maximum output is the output of an engine with its throttle valve fully opened under the condition that all the moving parts are properly worn in after the initial break-in period.

A new engine may not produce full maximum output while its moving parts are still not broken-in.

2-2 CONTINUOUS RATED OUTPUT

The continuous rated output is the output of an engine at optimum governed speed which is most favorable from the view point of engine's life and fuel consumption.

When the engine is installed on a certain equipment, it is recommended that the continuous output required from the engine be kept below this continuous rated output.

2-3 MAXIMUM OUTPUT

The maximum torque is the torque at the output shaft when the engine is producing maximum output at certain revolution.

2-4 PERFORMANCE CURVES

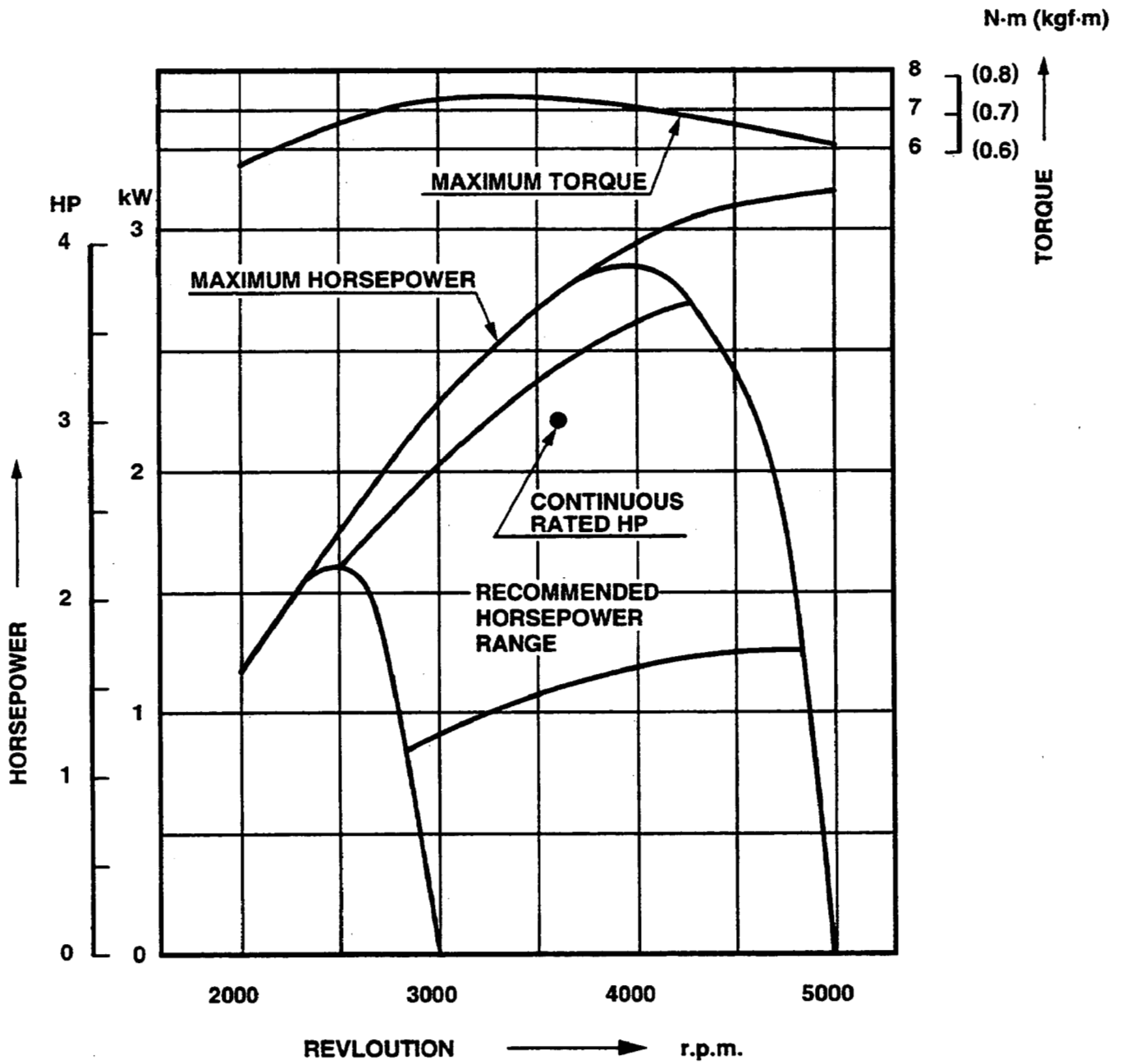

3. FEATURES

3-1 COMPACT, LIGHT WEIGHT AND HIGH POWER

Compact and light weight engine thanks to short connecting rod and aluminum cylinder.

3-2 SUPERB DURABILITY

Rugged design on each engine components and employment of high anti-vibration dust cover enable a long lasting durability even in harsh applications.

3-3 SIMPLE STRUCTURE, EASY MAINTENANCE

Maintenance free and high vibration proof have been achieved thanks to the crankcase built in governor system.

Easy start with decompression hole on exhaust system.

3-4 SUITABLE FOR REPLACEMENT ENGINE

Robin EC12 engine has the identical mounting flange as EC10 engines. Without any modification on your equipment, EC12 engine can replace EC10 engines.

3-5 OIL INJECTION SYSTEM (OIL INJECTION TYPE)

Oil and gasoline are placed into separate tanks. Therefore, mixing the fuel/oil which often can be troublesome, is now done automatically by engine function.

Because the fuel is gasoline, the start ability of the engine for the reason can be improved.

Since only gasoline is in the carburetor, there will be no jet choking due to the deterioration of oil.

The mixture ratio has become leaner, which will decrease white smoke during operation.

4. GENERAL DESCRIPTION OF ENGINE COMPONENTS

4-1 ALUMINUM CYLINDER AND CRANKCASE

Aluminum die-cast cylinder with molded-in cast iron liner has intake, exhaust and scavenging ports on the liner. For easy starting, decompression hole is implemented on the exhaust port.

Crankcase is divided into two pieces : crankcase 1 (Flywheel side) and crankcase 2 (P.T.O. side).

Governor chamber is built in the crankcase 2 and gasoline-oil mixture fuel lubricates the governor system.

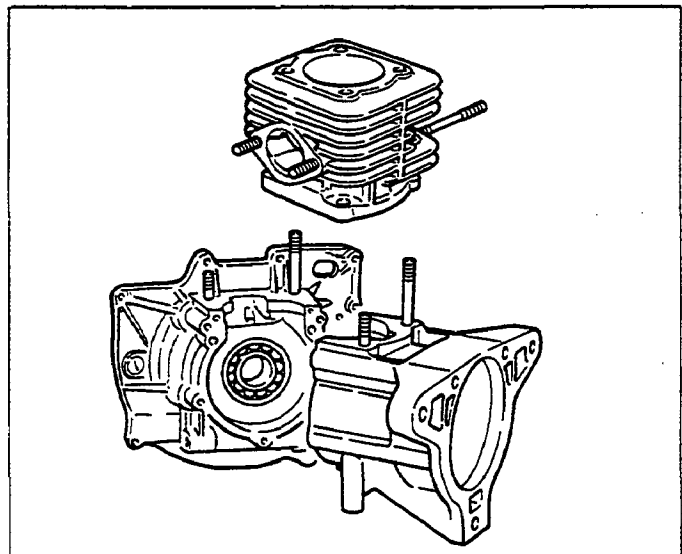

Fig. 4-1

4-2 CYLINDER HEAD

Aluminum die-cast made cylinder head has semi-sphere shaped combustion chamber for optimal combustion and higher efficiency.

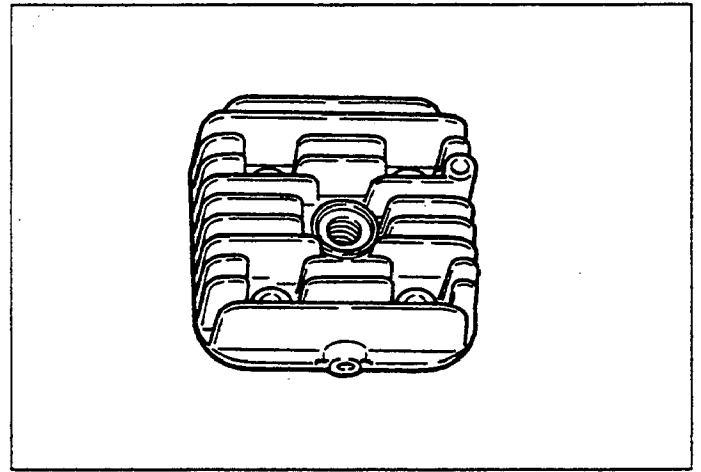

Fig. 4-2

4-3 CRANKSHAFT AND CONNECTING ROD

Forged steel crankshaft assembled with hardened crank pin and connecting rod, precision balanced for low engine vibration, durability, greater shock loading resistance and longer life. Needle bearings are implemented on both ends of the connecting rod. As these parts are press-fitted together by special jig and are unable to be disassembled, crankshaft assembly needs to be serviced in case crankshaft or connecting rod need to be replaced.

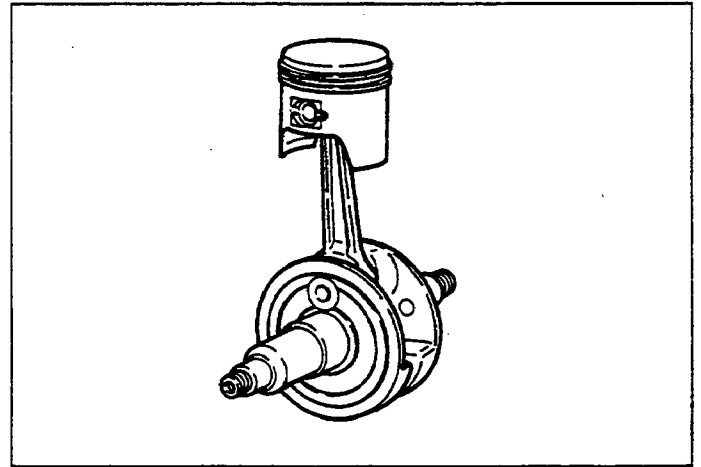

Fig. 4-3

4-4 PISTON AND PISTON RINGS

High strength aluminum alloy made piston equips two piston rings. To avoid piston ring rotation, knocks are pressed in piston ring grooves. Top ring is key-stone type and is chromium plated. Second ring is a plain type and is parkerlized.

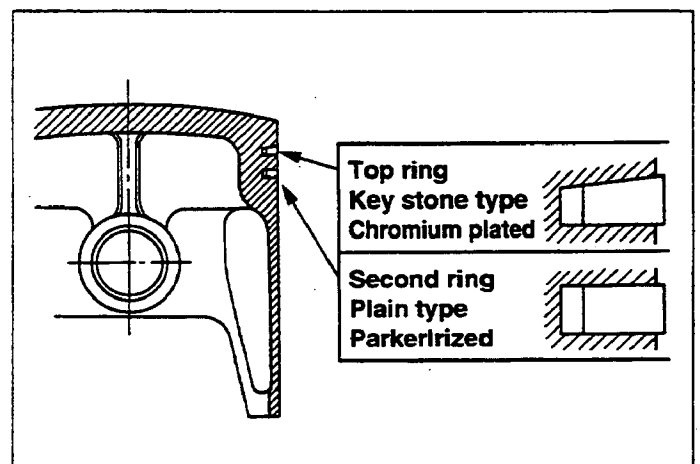

Fig. 4-4

4-5 ALL SPEED GOVERNOR

Rapid response mechanical flyweight type governor system is fully lubricated with oil mixed fuel for long life and which enables more precision speed regulation and better reliability.

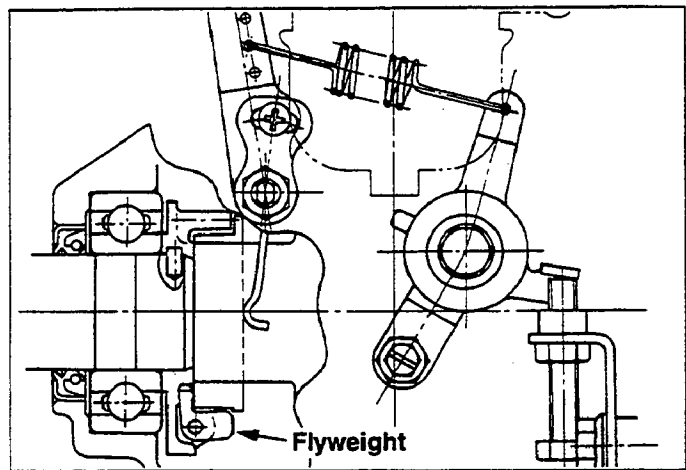

Fig. 4-5

4-6 COOLING SYSTEM

Forced air cooling is done by flywheel fan. Aluminum die-cast flywheel fan ensures better cooling and durability.

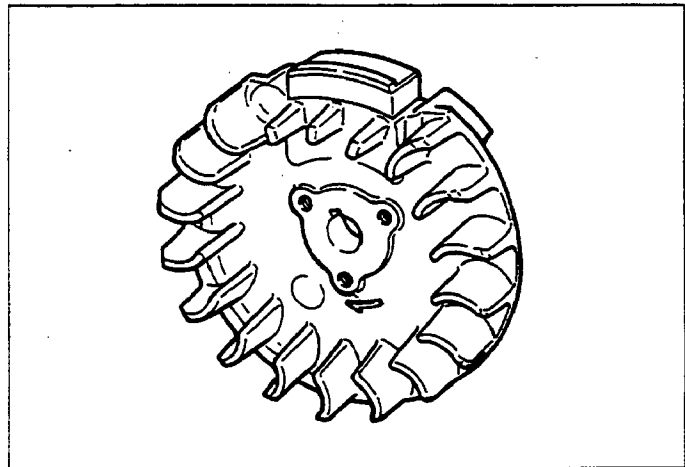

Fig. 4-6

4-7 CARBURETOR

EC12 is equipped with a horizontal draft carburetor that has a float controlled fuel system and a fixed main jet. Carburetor is calibrated carefully for easy starting, good acceleration, low fuel consumption and sufficient output.

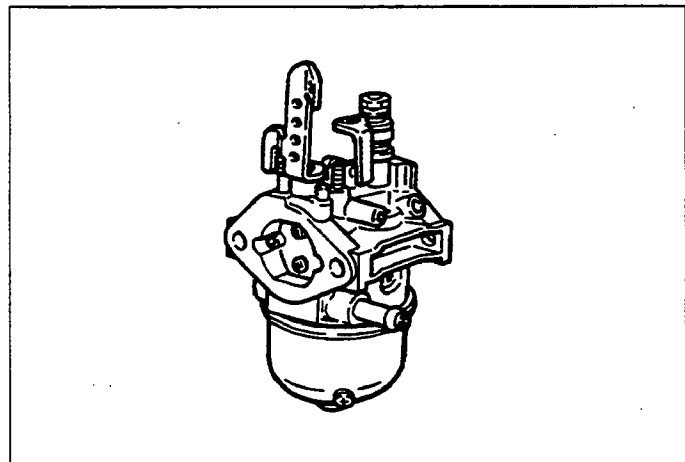

Fig. 4-7

4-8 AIR CLEANER

Rugged semi-wet dual stage air cleaner with high efficiency, ease of service and longer engine life.

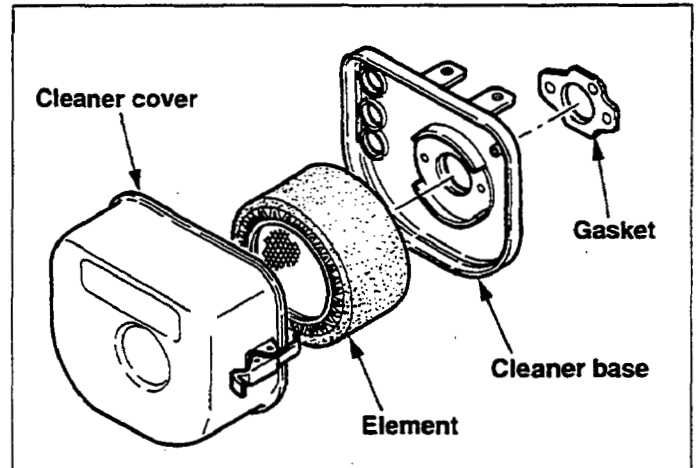

Fig. 4-8

4-9 IGNITION SYSTEM

Solid state, high energy electric ignition which referred to as T. C. I. (Transistor Controlled Ignition) gives more precise ignition timing, no breaker points to service, ease of maintenance and longer spark plug life. Ignition system is consisted of flywheel magneto and ignition coil. Flywheel is installed on crankshaft and ignition coil is on crankcase. Ignition timing is 18 BTDC. (Before Top Dead Center)

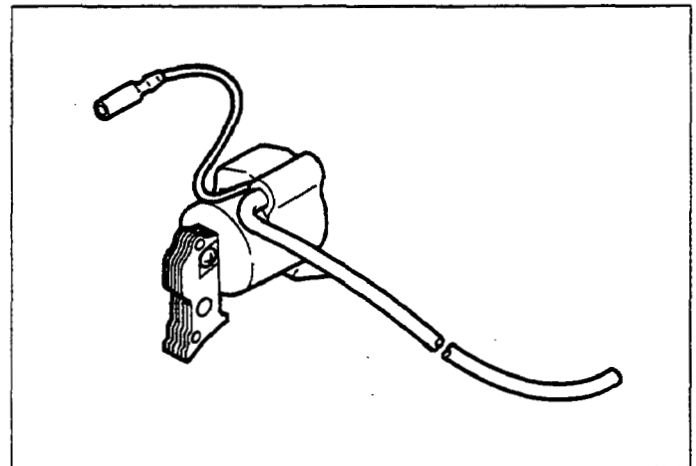

Fig. 4-9

4-10 OIL INJECTION SYSTEM

The oil injection system is a device that uses an oil pump directly driven by a crankshaft to forcefully feed lubrication oil to the air intake port of a cylinder. According to engine speed, the appropriate amount of oil is measured and fed.

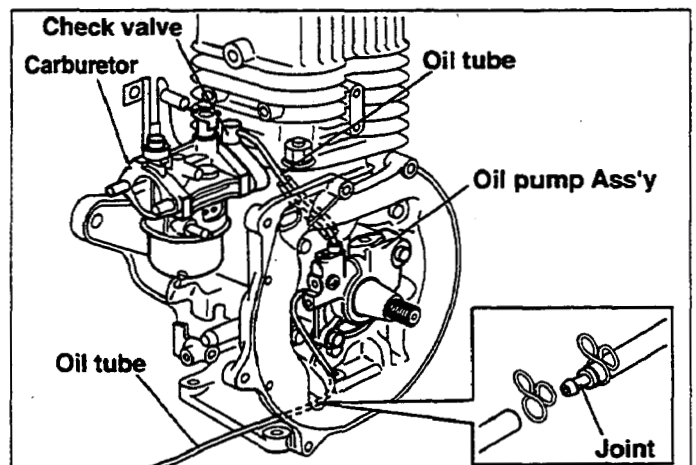
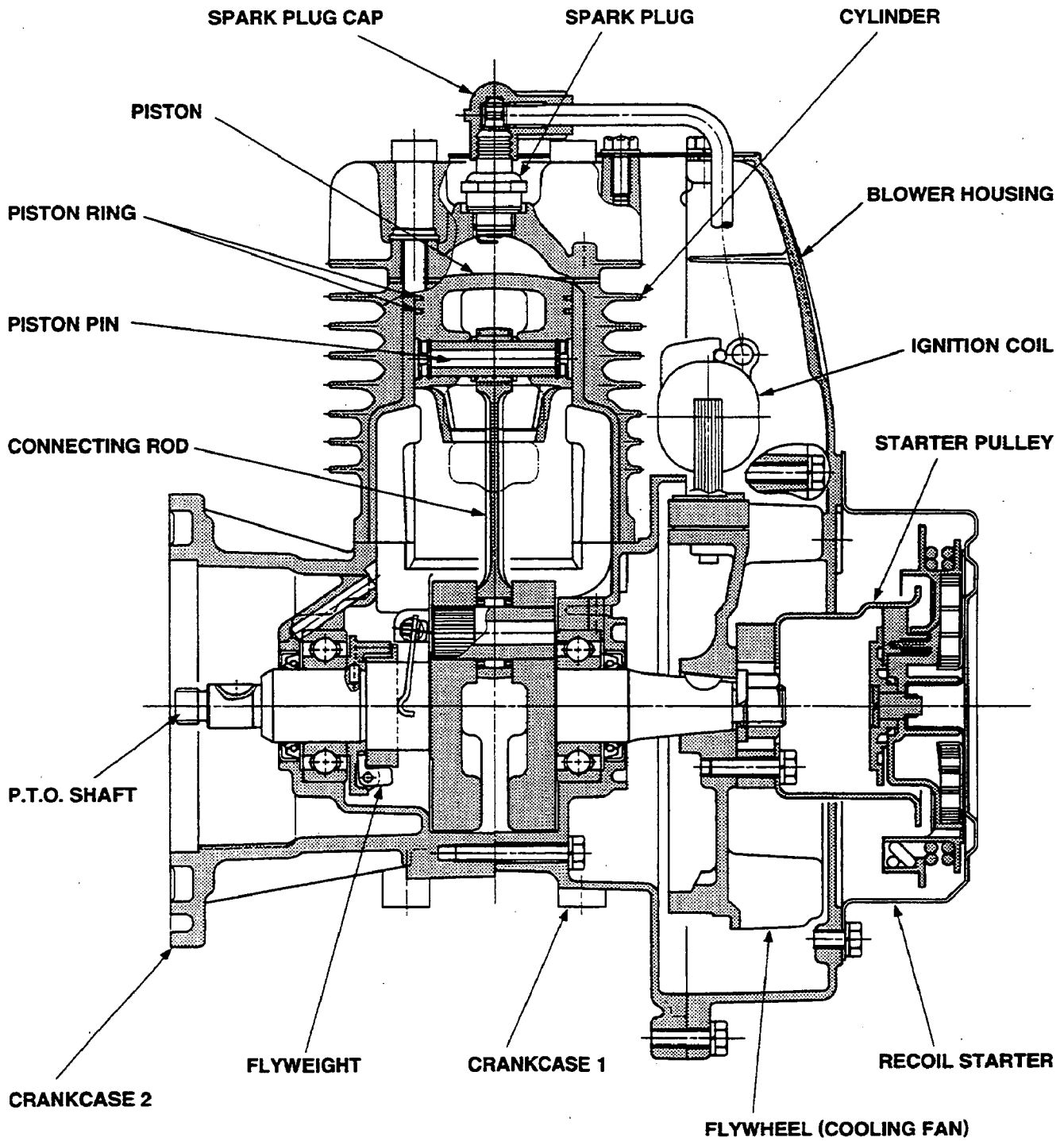
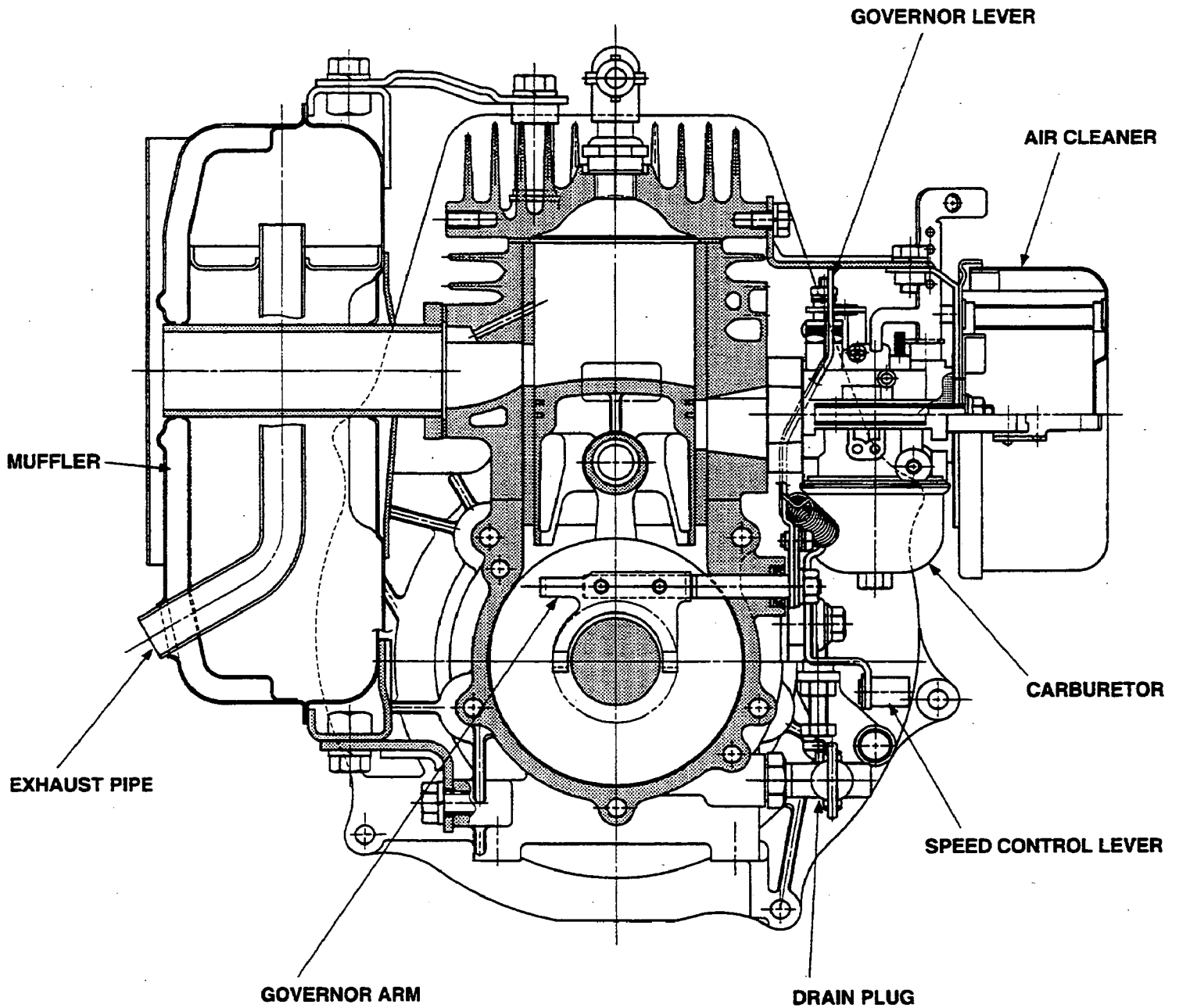

Fig. 4-10

4-11 SECTIONAL VIEW OF ENGINE

*EC12D STD.





***EC12D OIL INJECTION TYPE**

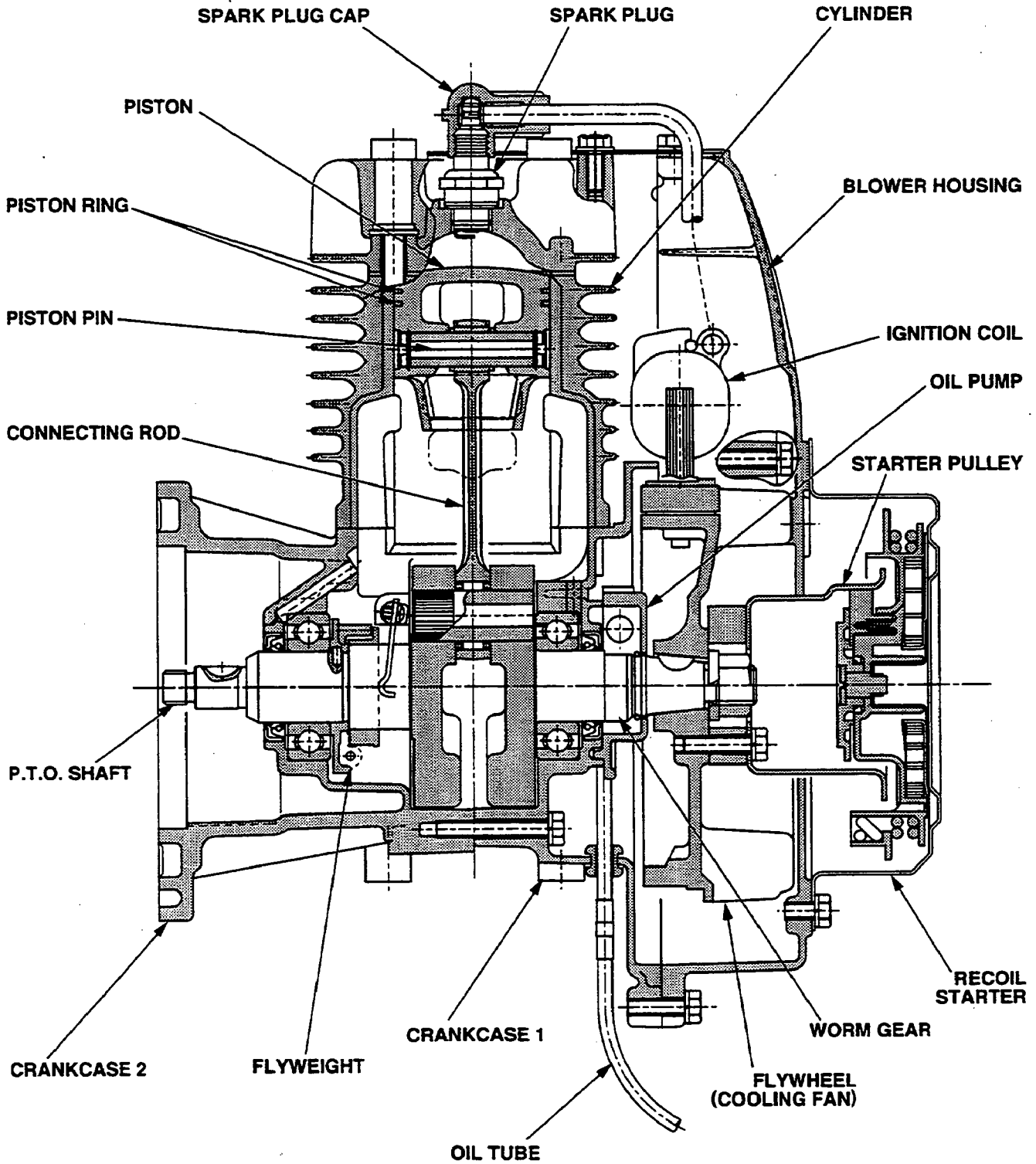

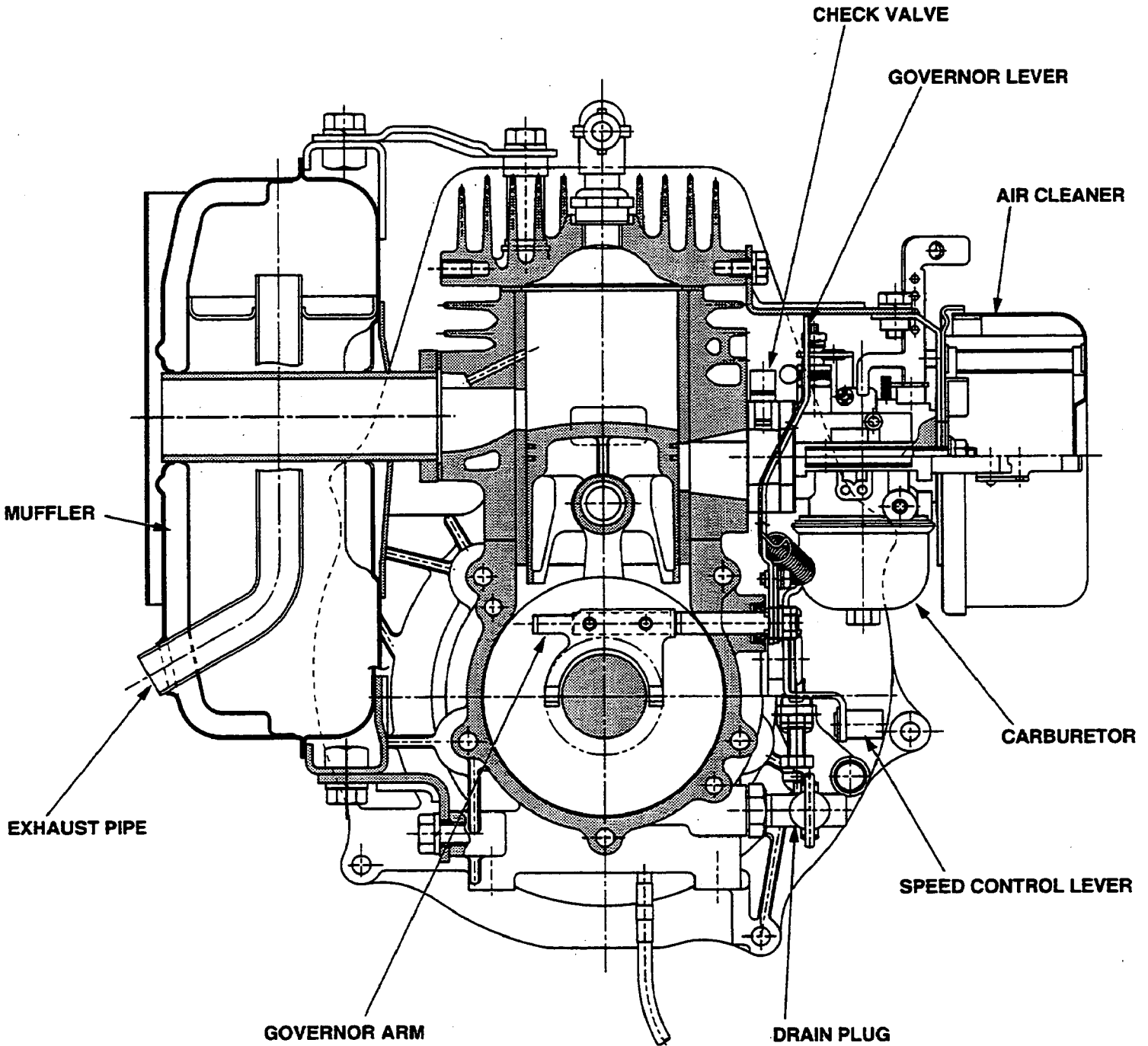

5. DISASSEMBLY

5-1 PREPARATIONS AND SUGGESTIONS

- (1) When disassembling the engine, memorize the locations of individual parts so that they can be reassembled correctly. If you are uncertain of identifying some parts, it is suggested that tags be attached to them.
- (2) Have boxes ready to keep disassembled parts by group.
- (3) To prevent losing and misplacing, temporarily assemble each group of disassembled parts.
- (4) Carefully handle disassembled parts, and clean them with washing oil if necessary.
- (5) Use the correct tools in the correct way.

5-2 SPECIAL TOOL

Tool No.	Tool	Use
209-95004-07	Flywheel puller with bolt	For pulling off the flywheel

Table. 5-1

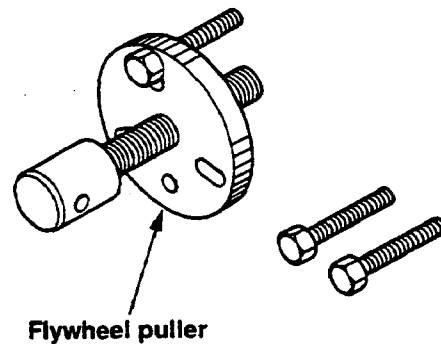

Fig. 5-1

5-3 DISASSEMBLY PROCEDURES

Step	Part to remove	Procedures	Remarks	Tools
1.	Air cleaner	(1) Remove air cleaner cover and element.		
		(2) Detach air cleaner bracket. M6 × 12mm bolt and spring washer 2 pcs on air cleaner 1 pc. on cylinder		
		(3) Remove cleaner base. M6 Self lock nut2 pcs	Detach air vent pipe from carburetor.	10mm box wrench

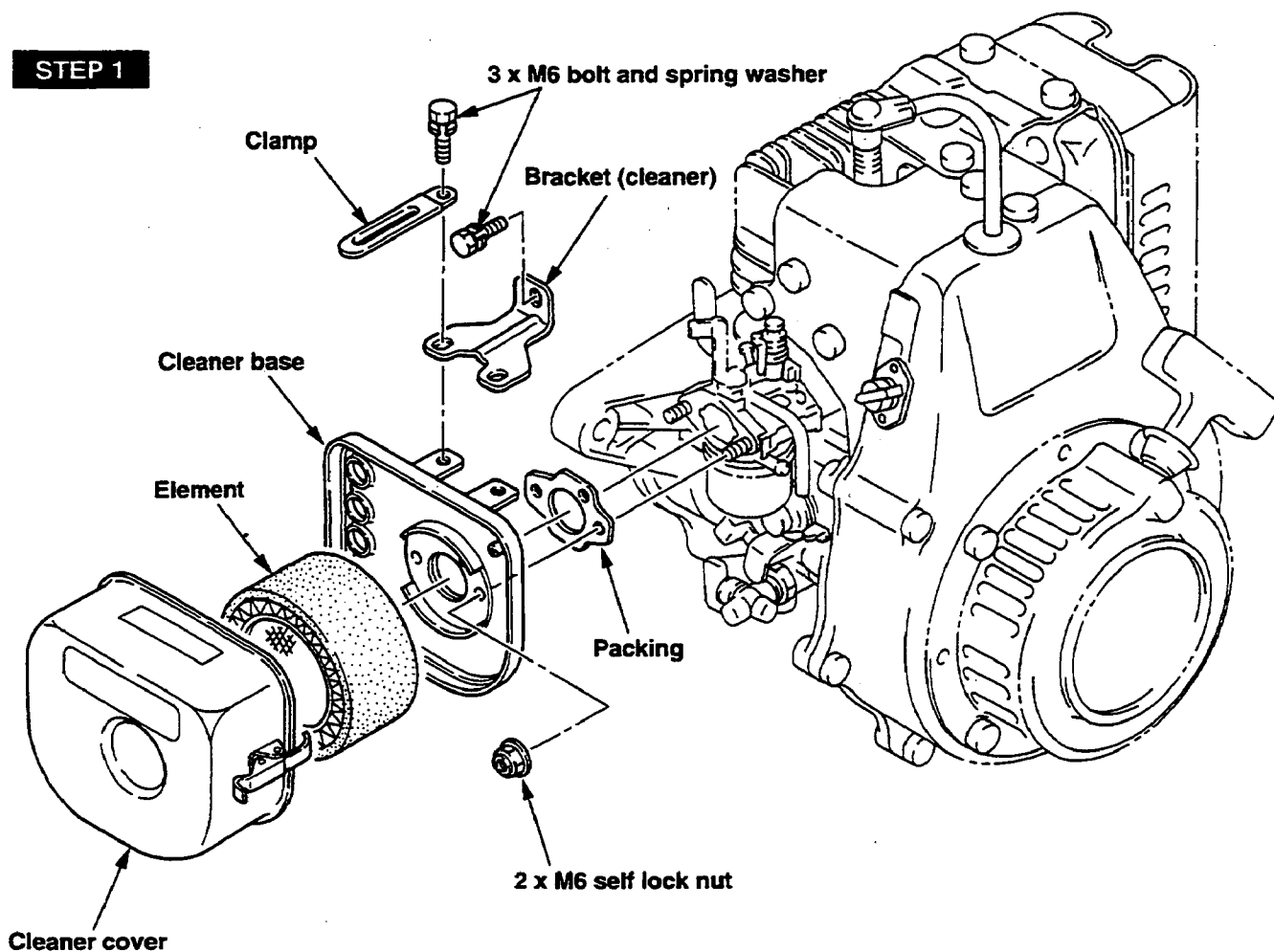

Fig. 5-2

Step	Part to remove	Procedures	Remarks	Tools
2.	Carburetor	(1) Close fuel valve.		
		(2) Disconnect fuel hose from carburetor.		
		(3) Remove carburetor carefully unhooking governor rod and rod spring from governor lever.	Be careful not to bend governor rod or stretch governor spring.	

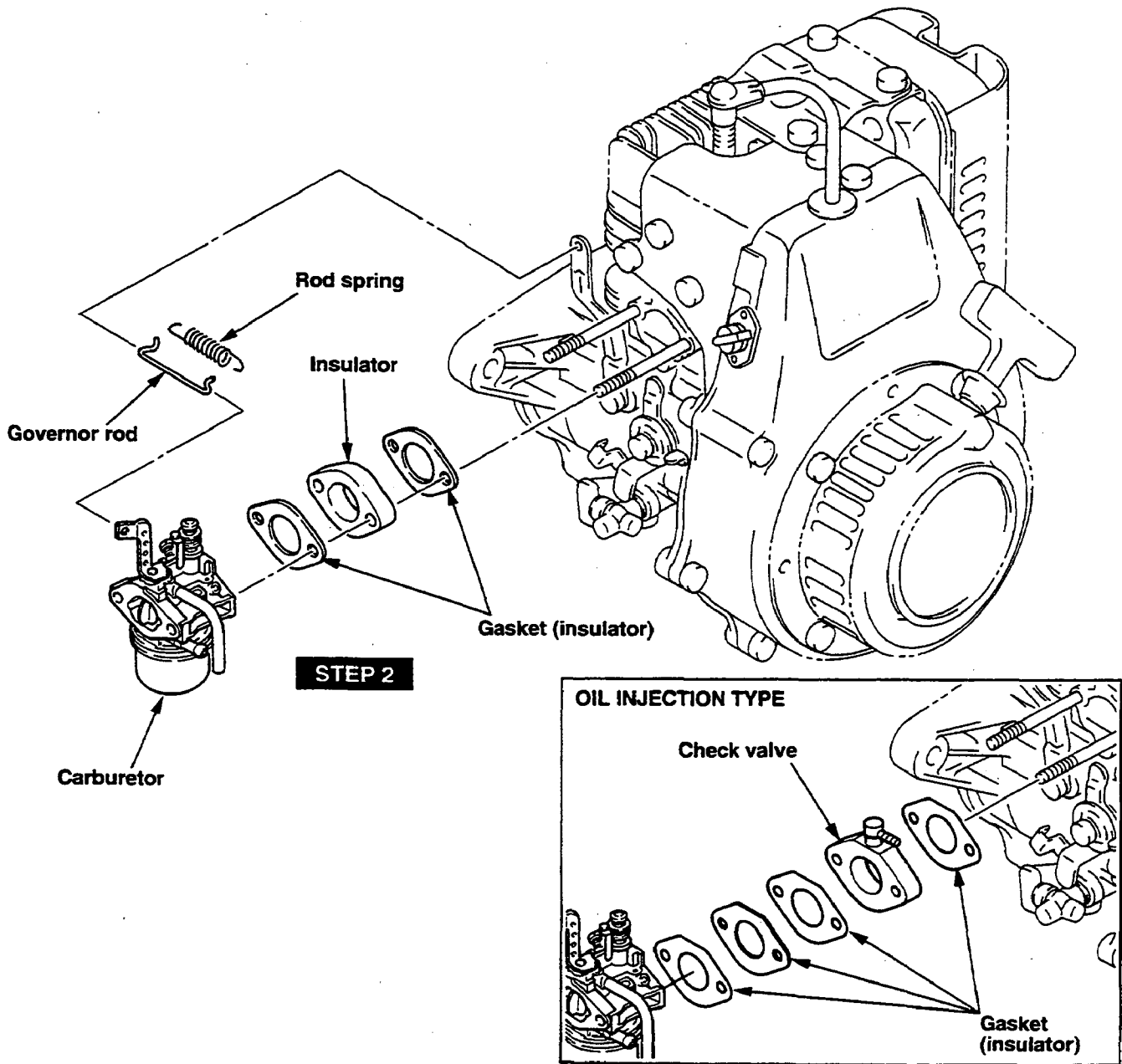

Fig. 5-3

Step	Part to remove	Procedures	Remarks	Tools
3.	Speed control lever and governor lever	(1) Unhook governor spring from governor lever.	Unless it is required, do not remove control lever and governor lever from carankcase.	Needle nose
		(2) Remove Cover, washer (fiber) and speed control lever. M6 × 8mm flange bolt1 pc.	Note governor spring hole on governor lever.	10mm Socket wrench
		(3) Detach governor lever together with adjusting plate. M6 nut1 pc.		

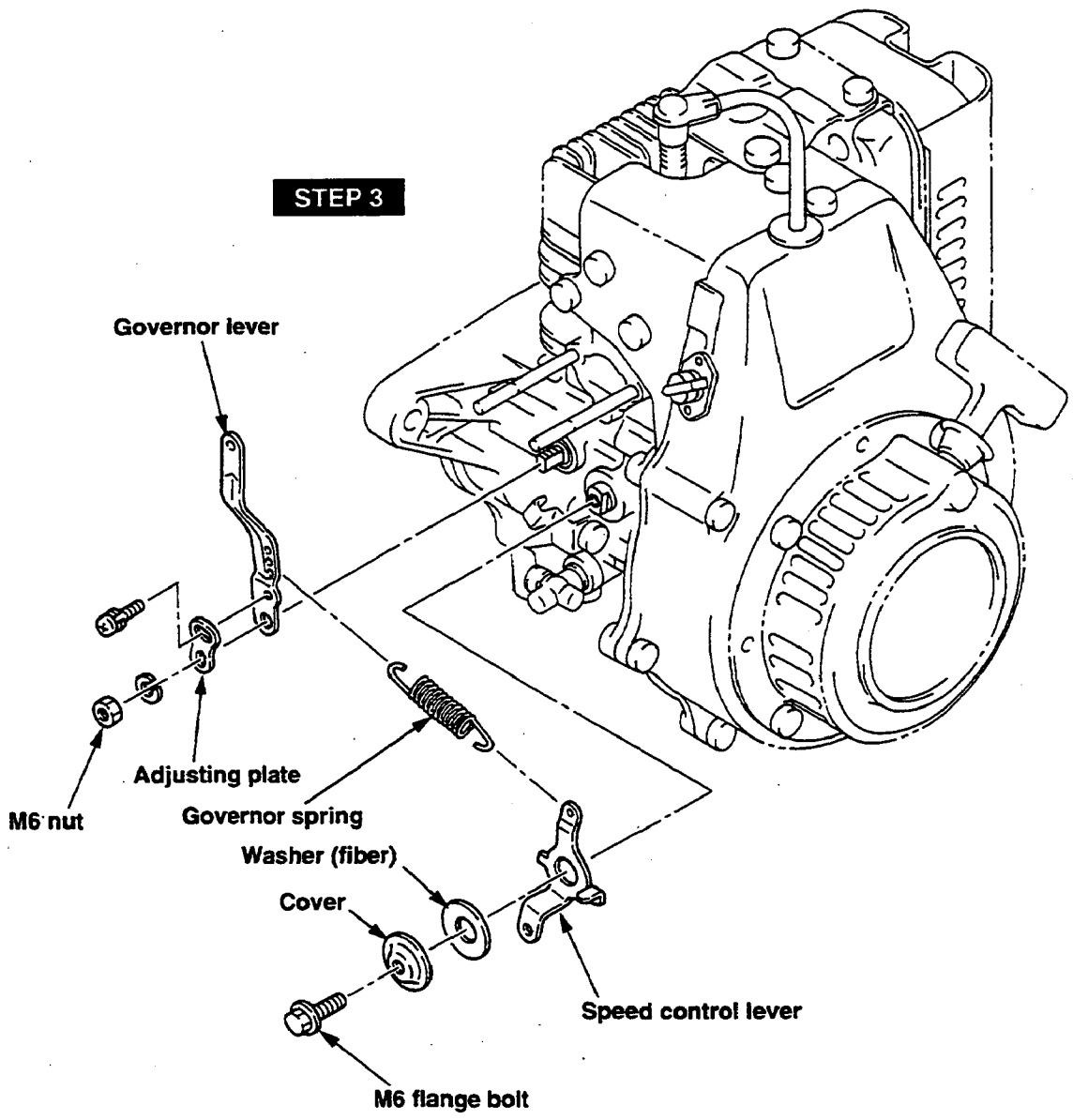

Fig. 5-4

Step	Part to remove	Procedures	Remarks	Tools
4.	Muffler	(1) Remove muffler bracket on the top. M8 × 16mm bolt and washer4 pcs		12mm Socket wrench
		(2) Remove muffler bracket on the bottom. M8 × 16mm bolt and washer3 pcs		
		(3) Remove muffler. M8 brass nut2 pcs		

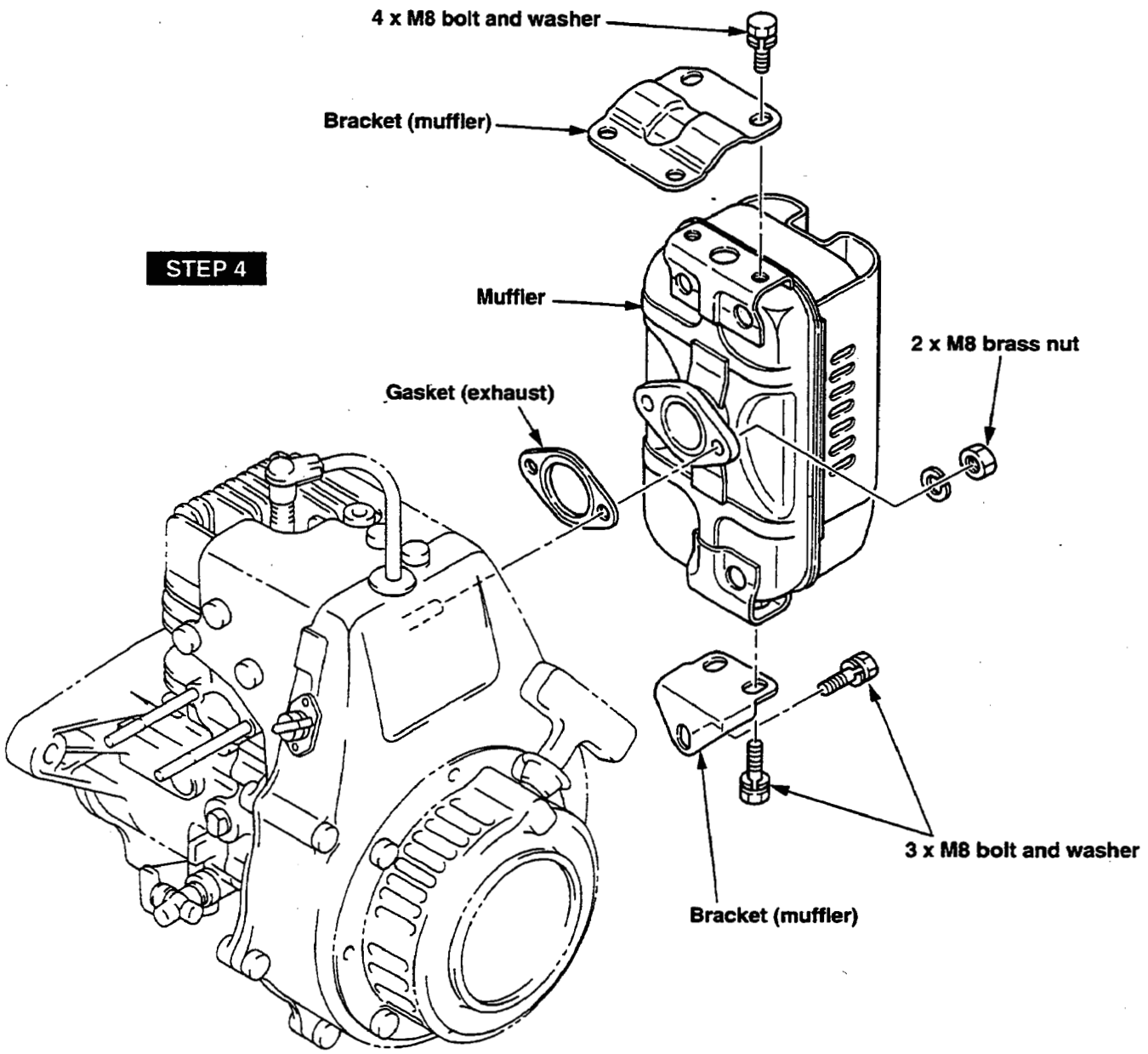

Fig. 5-5

Step	Part to remove	Procedures	Remarks	Tools
5.	Cylinder baffle	(1) Detach spark plug cap. (2) Unplug spark plug cap from high tension cord. (3) Remove cylinder baffle. M6 × 16mm tapping bolt3 pcs M6 × 8mm flange bolt1 pc. M6 × 12mm flange bolt1 pc. (4) Clamp on engine stop switch wire to be removed same time.		10mm Socket wrench
6.	Recoil starter, Starter pulley and spacer	(1) Remove recoil starter. M6 × 12mm bolt and washer4 pcs (2) Remove starter pulley and spacer. M6 × 25mm bolt and washer3 pcs		10mm Socket wrench
7.	Blower housing	(1) Disconnect stop switch wire. (black) (2) Remove blower housing from crankcase. M6 × 20mm bolt and washer3 pcs M6 × 55mm bolt and washer2 pcs (3) Clamp on blower housing to be removed same time. (4) Detach grommet on high tension cord.		10mm Socket wrench

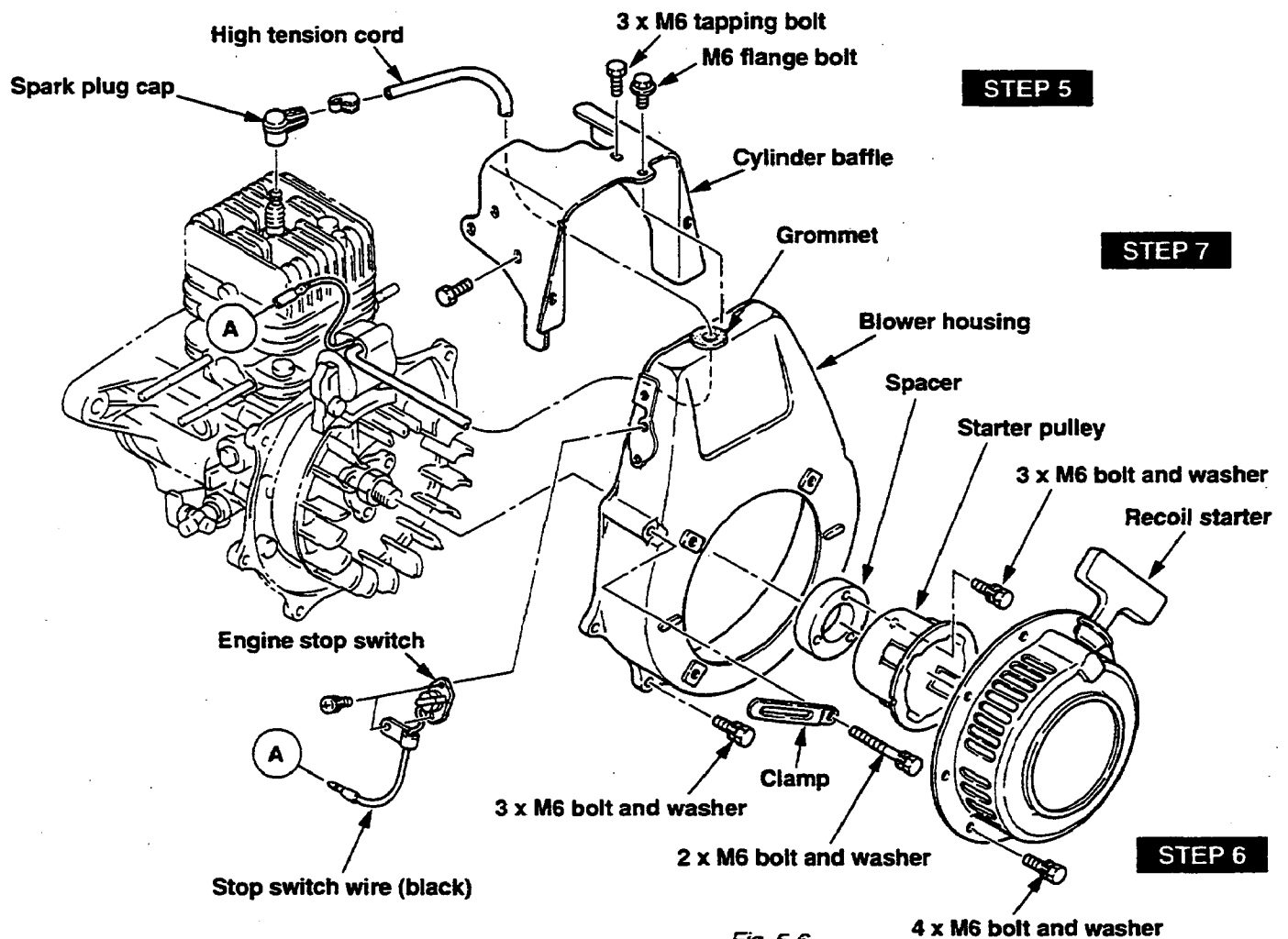

Fig. 5-6

Step	Part to remove	Procedures	Remarks	Tools
8.	Ignition coil	Remove ignition coil. M6 × 20mm bolt and washer2 pcs		10mm Socket wrench
9.	Flywheel	(1) Remove flywheel nut. M14 nut and spring washer1 pc.		19mm Socket wrench
		(2) Remove flywheel using flywheel puller. (See Fig. 5-8.)	Flywheel can easily be removed by striking the head of the center bolt of the flywheel puller with hammer.	Flywheel puller 209-95004-07
		(3) Remove the key from crankshaft.	Be careful not to lose the key.	
10.	Oil pump	(1) Remove the body of oil pump from crankcase. M6 × 20mm bolt and washer2 pcs (2) Take out the clip of the pump gear which fixed at the crankshaft.		

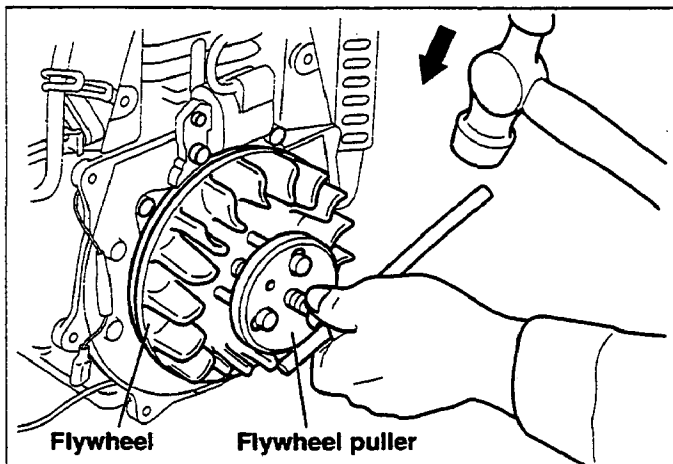

Fig. 5-8

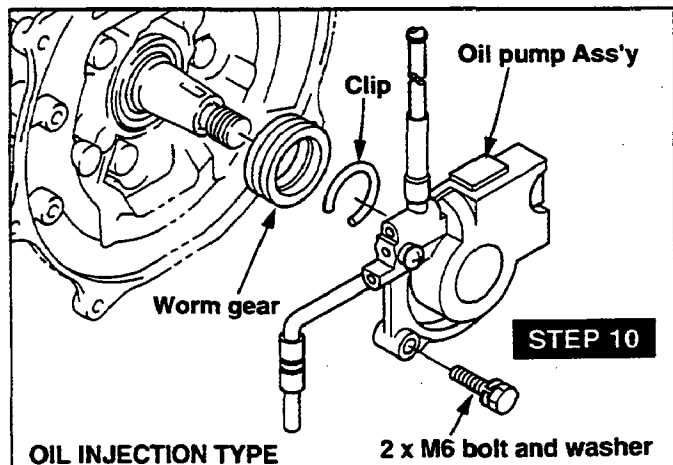

Fig. 5-9

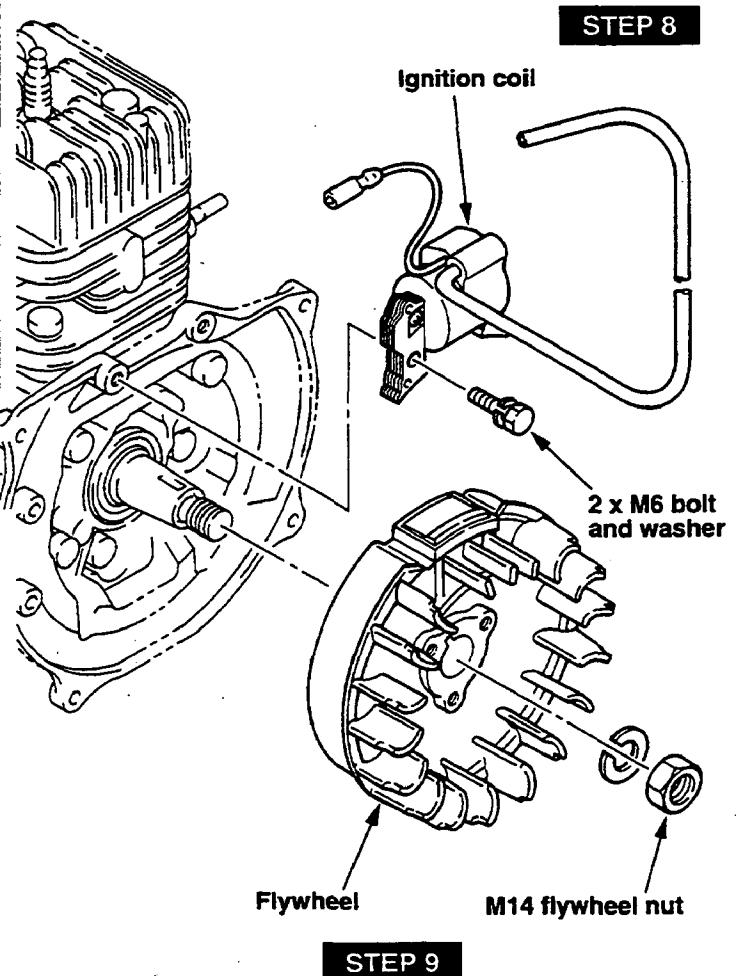

Fig. 5-7

Step	Part to remove	Procedures	Remarks	Tools
11.	Cylinder head	(1) Remove spark plug.	Champion CJ8 NGK BM6A	21mm
		(2) Remove cylinder head. M8×35mm bolt and washer*4 pcs * 2 pcs on muffler side are special bolt.	Gasket, between cylinder head and cylinder.	Plug wrench 12mm socket wrench
12.	Cylinder	Remove cylinder. M8 nut4 pcs		12mm socket wrench

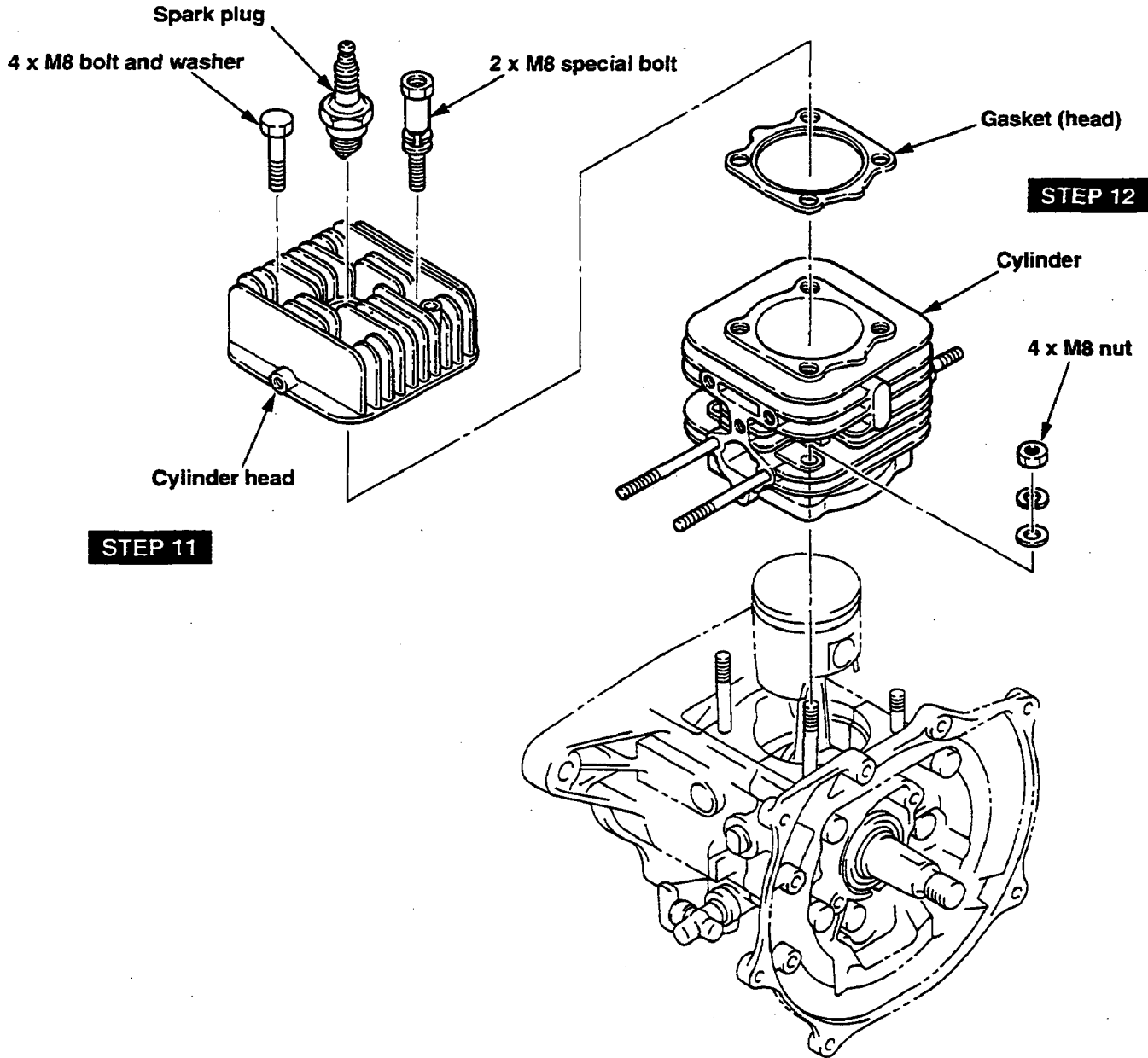

Fig. 5-10

Step	Part to remove	Procedures	Remarks	Tools
13.	Piston and piston pin	(1) Remove clips.	Be careful not to damage piston.	
		(2) Remove piston pin to remove piston and needle bearing.		
		(3) Remove piston rings from piston.	Be careful not to break the rings by spreading too much or twisting.	Ring expander

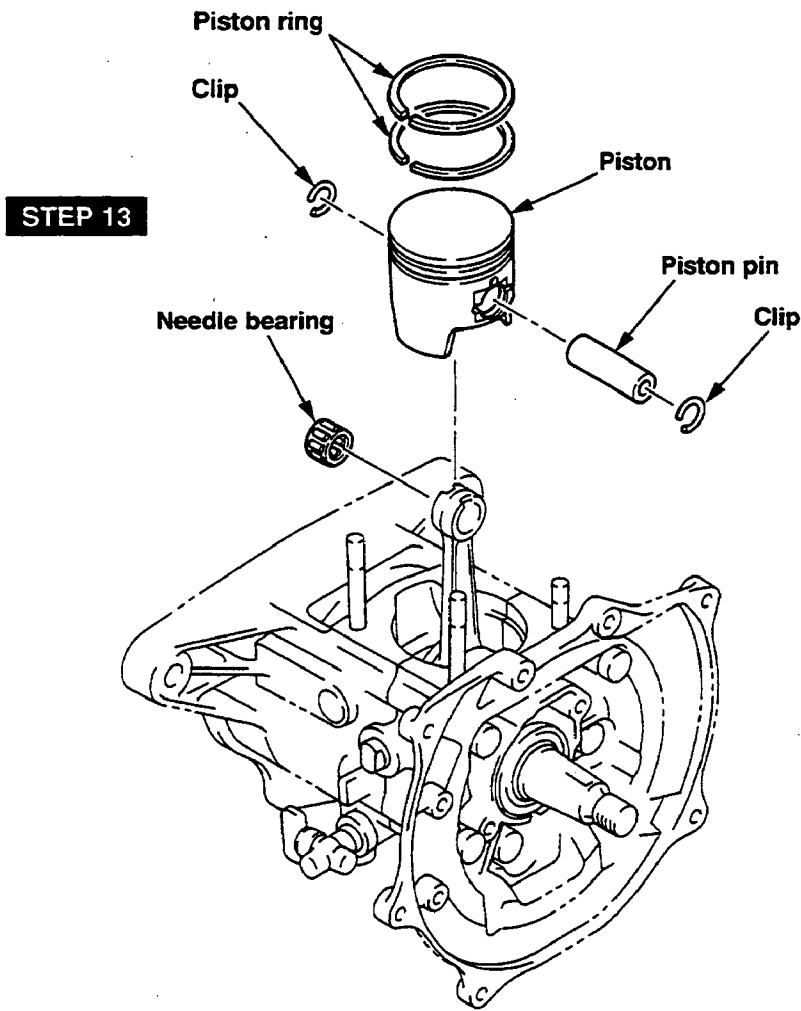

Fig. 5-11

Step	Part to remove	Procedures	Remarks	Tools
14.	Crankcase	Remove bolts fastening crankcase 1 and crankcase 2 together to remove crankshaft and governor sleeve M6 × 40mm bolt and washer 2pcs M6 × 55mm bolt and washer 3pcs		10mm Socket wrench

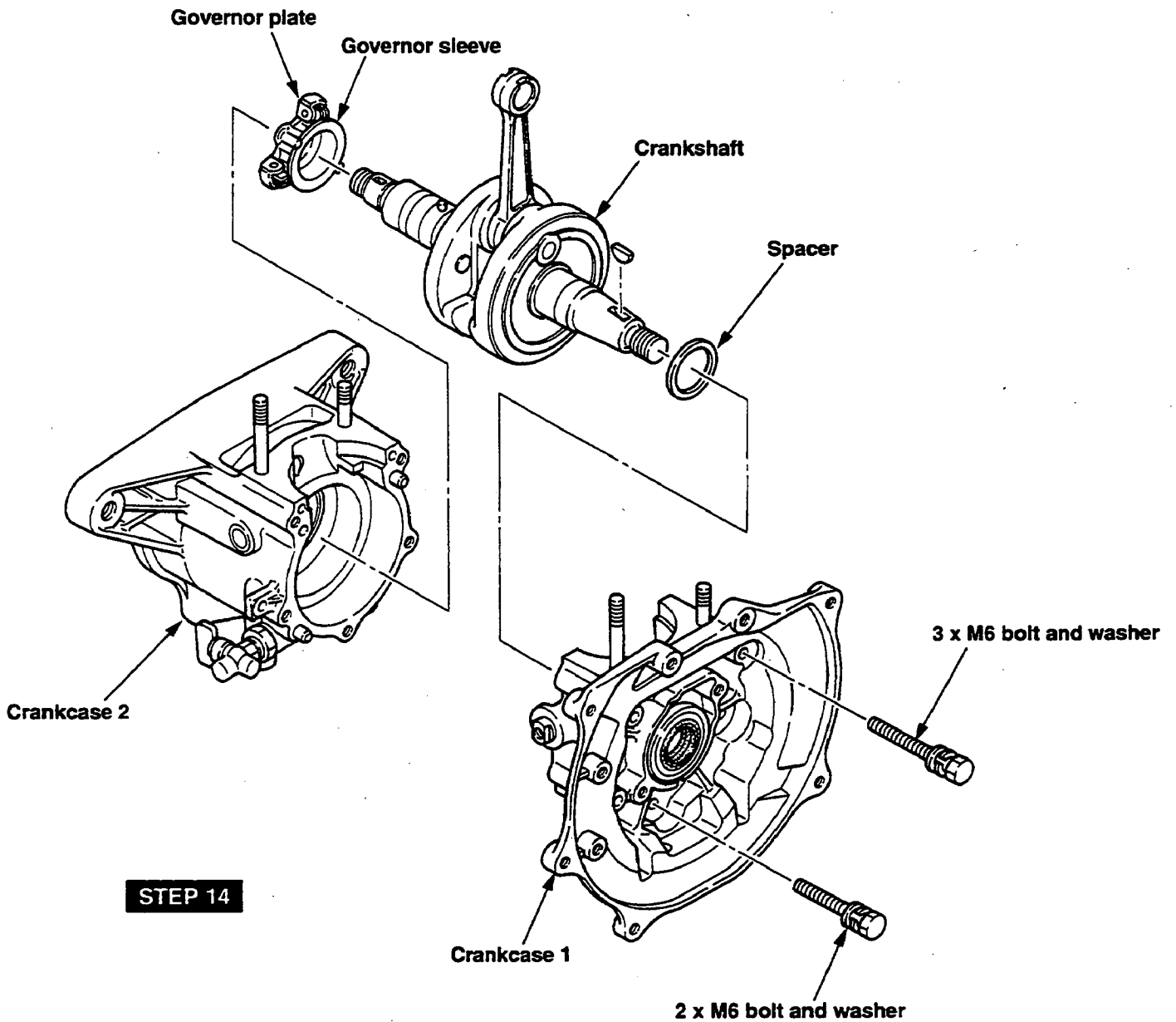

Fig. 5-12

6. REASSEMBLY

6-1 CLEANING BEFORE REASSEMBLY

- 1) Check all sliding and rotating parts, such as piston, cylinder, crankshaft and bearings for defect.
- 2) Wash the disassembled parts in kerosene to remove dust, dirt and contaminated oil thoroughly. Wash them twice, first time remove visible dirt roughly, and second time using fresh kerosene.
- 3) After washing, blow them thoroughly with compressed air.
- 4) Do not wash electric parts. Wipe them with clean cloth and dry them.
- 5) Accumulated carbon on the cylinder-head, gasket, piston, cylinder and inside the muffler to be carefully removed, and finish the piston with oil stone to get smooth surface.
- 6) Parts of carburetor to be washed carefully with gasoline and blow them thoroughly with compressed air.
- 7) Check the cable for any damage.
- 8) Air-cleaner element shall be washed in the detergent and dry thoroughly. Then put it to mixture of 2 to 4 kerosene and 1 engine oil, and assemble it after squeezed well.
- 9) Take special care not to contaminate the parts with dust and apply mobile oil on the surface in order to prevent rust.

6-2 CHECKS AND CORRECTIONS BEFORE REASSEMBLY

After disassembling and cleaning the engine parts, check them and, if necessary, correct them according to the section "**CLEARANCE DATA and LIMITS / TORQUE SPECIFICATIONS.**" Gaskets and rubber pipes shall be replaced with new ones.

6-3 PRECAUTIONS FOR REASSEMBLY

- (1) Clean parts thoroughly before reassembly. Pay most attention to cleanliness of piston, cylinder, crankshaft, connecting rod and bearings.
- (2) Take care not to contaminate the parts with dust during reassembly.
- (3) Check lip of oil seals. Replace oil seal if the lip is damaged.
Apply oil to the lip before reassembly.
- (4) Replace all the gaskets with new ones. Use only designated sealing agent. Do not apply oil to parts where packings or sealing agents are used.
- (5) Replace keys, pins, bolts, nuts, etc., if necessary.
- (6) Be sure to assemble those parts provided with alignment marks by bringing the marks in alignment.
- (7) Tighten bolts, nuts and screws to the correct torque specified. When there is no torque specification, tighten them to torque readings appropriate to the size.
Standard Tightening Torque for screws are as follows:

6mm	90 kgf-cm (6.5 ft. lb)
8mm	250 kgf-cm (18 ft. lb)
10mm	370 kgf-cm (26.7 ft. lb)

If small screws are over torqued, they may get broken. When tightening several screws fastening a single part, tighten them all evenly, by alternately tightening diagonally located parts.

- (8) Apply oil to rotating and sliding parts.
- (9) Check and adjust clearances and end plays where specified in this manual.
- (10) During the assembly, turn the moving part by hand to check for friction and noise.
- (11) After the completion of reassembly, turn the engine by hand and check if there is any disorder or loose members.

6-4 REASSEMBLY PROCEDURES

6-4-1 CRANKCASE 1

- (1) Before reassembling the crankcase, check bearing and oil seals.
If there is any damage, replace them with new ones.
- (2) Put crankcase 2 with mounting flange down on a firm stand so that crankshaft move freely when it is installed.
- (3) Apply oil to the bearings of crankcase and ascertain that there is no warp on the lip of oil seals.
- (4) Put governor plate and governor sleeve on the bearing of crankcase 2.
Place the notch of governor plate to cylinder (or spark plug) side.
- (5) Assuring that knock pin on crankshaft and notch on governor plate are aligned, assemble the crankshaft with press (or tap it with a soft hammer) taking care not to damage the oil seal.

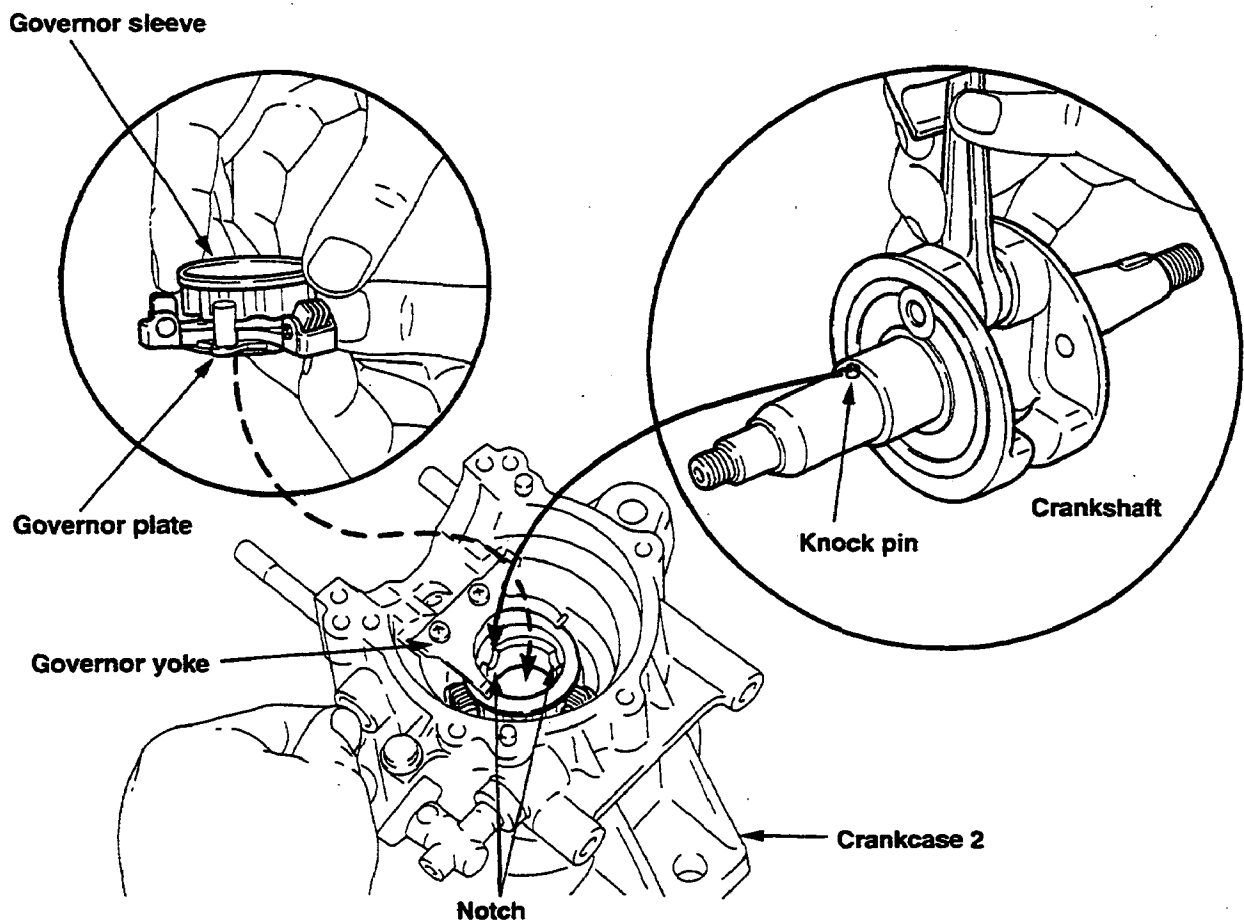

Fig. 6-1

6-4-2 ADJUST CRANKSHAFT END PLAY

Select one spacer so that the crankshaft end play to be 0- 0.2mm(0" - 0.008")

SPACER THICKNESS 0.1 (0.004") P/N 161-25001-03
 0.3 (0.012") P/N 161-25002-03

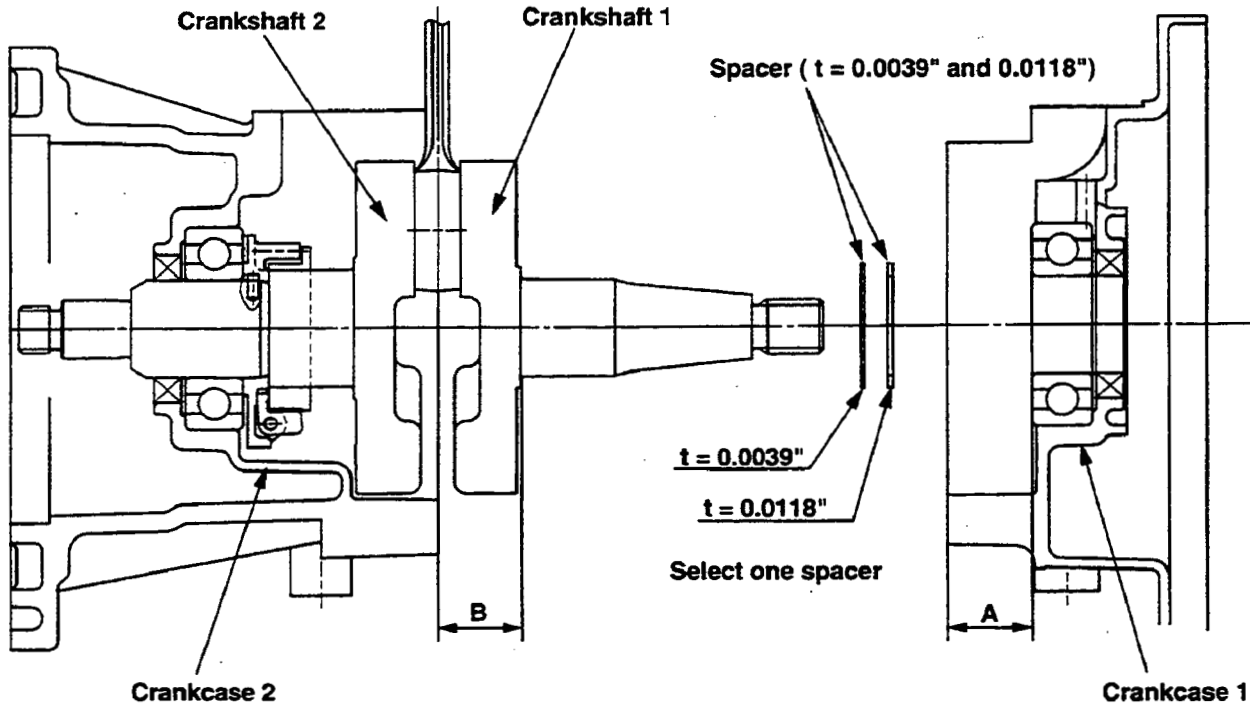

Fig. 6-2

6-4-3 CRANKCASE 2

- (1) Clean the join of both crankcases and apply sealing agent (THREE BOND 1215 or equivalent). Joint crankcase 1 with press (or tap it with a soft hammer). Fasten them with bolts.

M6 × 40 bolt and washer Ass'y ··· 2 pcs

M6 × 55 bolt and washer Ass'y ··· 3 pcs

TIGHTENING TORQUE	
8.8 ~	9.8 N · m
90 ~	100 kgf · cm
6.5 ~	7.2 ft · lb

CAUTION: When reassembling the crankcase, tighten the diagonally located pairs of bolts according to the specified tightening torque.

NOTE: After reassembling the crankshaft to the crankcase, check if the crankshaft rotates smoothly.

6-4-4 PISTON RINGS

If an expander is unavailable, install the ring by placing the open ends of the ring on first land of piston, then spread the ring only far enough to slip over the piston and into the correct groove.

- CAUTION:**
- 1) Be extremely careful not to distort and break the ring.
 - 2) Put the open ends of piston rings to the lock pins in the grooves.
(This is to prevent the rings from rotation while operating the engine.)
 - 3) Assemble the rings in the order of the second ring and then top ring.
Top ring Chromium plated surface (looks white silver in color)
Second ring Parkerized surface (looks dark in color)

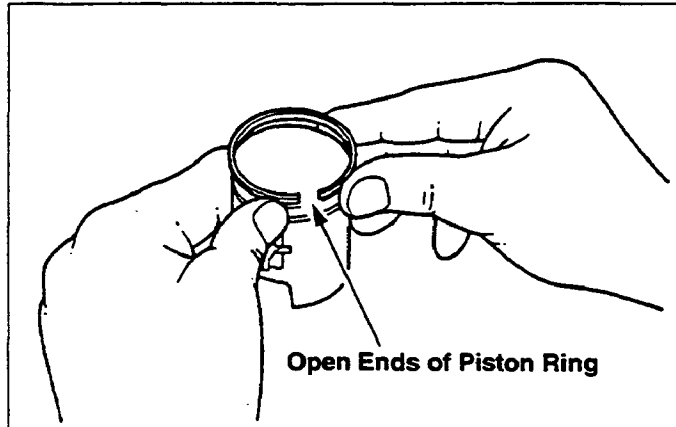

Fig. 6-3

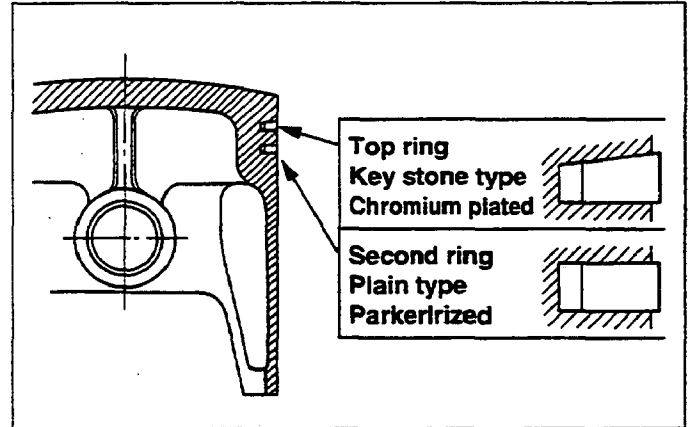

Fig. 6-4

6-4-5 PISTON

- 1) Position the "F" mark of piston top to flywheel side and reassemble the piston and connecting rod with the needle bearing by gently striking the piston pin.

CAUTION : Apply oil to the needle bearing before reassembling it to piston pin.

- 2) Assemble piston pin clip.

CAUTION : Replace piston pin clip if there is any looseness after reassembling it.

- 3) Be sure that piston and connecting rod move smoothly after reassembled.

6-4-6 CYLINDER

- 1) Clean carbon deposit from cylinder head and combustion chamber.

CAUTION : If carbon deposits are not removed the piston and inner surface of cylinder may be damaged when reassembling.

- 2) Wipe oil from crankcase joint surface and apply sealing agent (THREE BOND 1215 or equivalent).
- 3) Replace cylinder gasket with a new one.
- 4) Placing open ends of piston rings to the lock pins in the grooves. Install piston to the cylinder.

NOTES : (1) Apply oil to piston and piston pin before reassembling.

(2) Mark sure that intake and exhaust ports are facing the right side

(3) After assembling cylinder make sure the crankshaft rotates smoothly.

M8 nut and washer 4pcs.

TIGHTENING TORQUE	
17.6	~ 21.5 N · m
180	~ 220 kgf · cm
13.0	~ 15.9 ft · lb

6-4-7 CYLINDER HEAD

- 1) Clean carbon from combustion chamber and dirt from between the cooling fins of cylinder head. Check its mounting face for distortion.
- 2) Use new cylinder head gasket.

NOTE : Cylinder head gasket must be placed folded edge up. (Toward cylinder head)

- 3) Install the cylinder head so that the alignment marks on the cylinder head and cylinder match.
M8 × 35 mm bolt and washer ···· 4pcs.

NOTE : Special bolts are to be installed on the muffler side of the cylinder head.

TIGHTENING TORQUE	
17.6 ~	21.5 N · m
180 ~	220 kgf · cm
13.0 ~	15.9 ft · lb

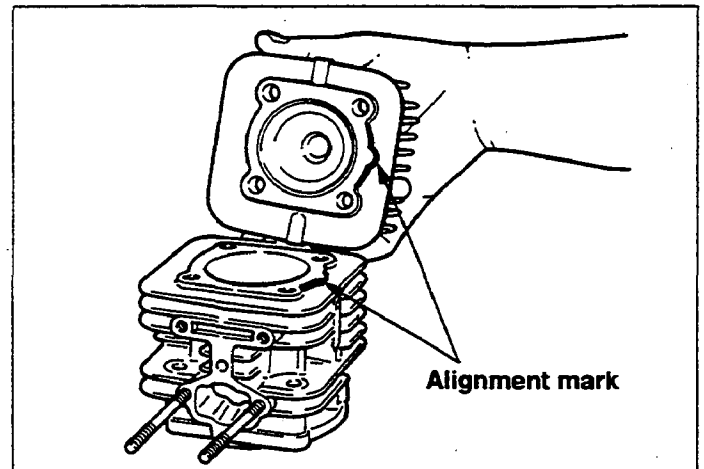

Fig. 6-5

6-4-8 SPARK PLUG

Check Carbon deposits and wear on the spark plug terminal.
Replace spark plug with a new one if necessary.

Spark Plug : CHAMPION CJ8 or
NGK BM6A

TIGHTENING TORQUE	
NEW SPARK PLUG	RETIGHTENING
11.8 ~ 14.7 N · m	24.5 ~ 29.4 N · m
120 ~ 150 kgf · cm	250 ~ 300 kgf · cm
8.7 ~ 10.8 ft · lb	18.0 ~ 21.7 ft · lb

6-4-9 OIL PUMP (OIL INJECTION TYPE)

1) Worm gear

Mesh each gear at the proper position, then secure with C-clip.

Put grease on drive worm gear about 0.5 cc (equivalent to Shell Albania #3)

After assembling pump, the crankshaft should be rotated a few times by hand to be spread the grease.

2) How to eliminate air from oil tube

Remove the tube from oil pump inlet.

Allow the tube to fill with oil, which will force out the remaining air.

After checking, reassemble the tube to the inlet, then clamp securely.

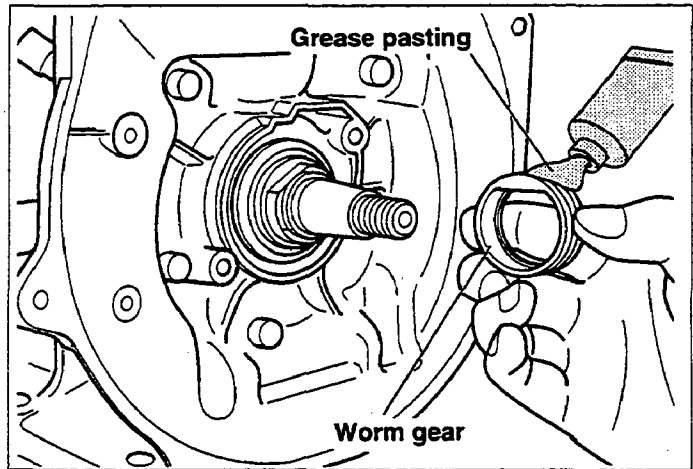

Fig. 6-6

CAUTION : 1) When air is in the oil tube, insufficient oil will be carried to the engine and engine size will result.

- 2) When air is observed in the tube, air must be eliminated by the above procedure. Then mixed fuel/oil must be used until air has been eliminated from entire system. After running 1 mixed fuel/oil tank, you may continue with gasoline only. No need to**

6-4-10 FLYWHEEL

1) Wipe off oil and grease thoroughly from the tapered portion of the crankshaft and flywheel.

2) Put the woodruff key in the key way of crankshaft.

3) Install the flywheel to the crankshaft. Tighten the nut with spring washer.

M14 Nut with spring washer..... 1 pc.

TIGHTENING TORQUE	
38.2	~ 41.1 N · m
390	~ 420 kgf · cm
28	~ 30 ft · lb

6-4-11 IGNITION COIL

When installing the ignition unit on the crankcase, use a non-metallic feeler gauge to measure the air gap between the ignition coil and flywheel. The ignition coil can be moved to adjust the air-gap by loosening its hold down screws.

M6 × 20mm bolt and washer ····· 2 pcs.

AIR GAP
0.3 ~ 0.5mm
0.012 ~ 0.020 in

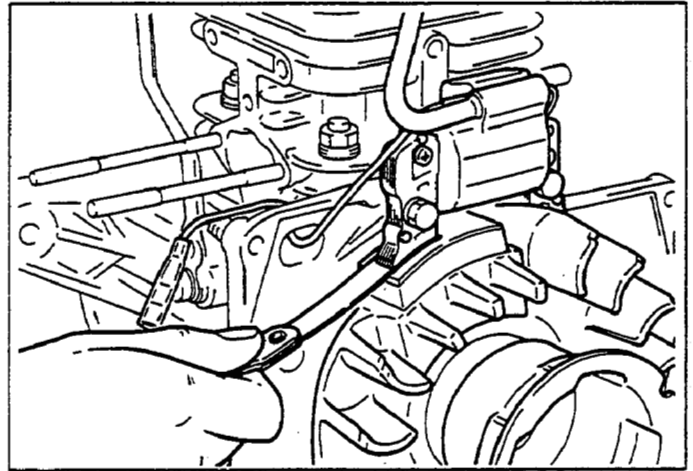

Fig. 6-7

6-4-12 BLOWER HOUSING

Through high tension cord from inside the blower housing and put the grommet on the cord to the blower housing. Then install the blower housing to the crankcase. A clamp is fastened together on the air cleaner side bolt.

M6 × 20mm bolt and washer ····· 3 pcs.

M6 × 55mm bolt and washer ····· 2 pcs.

6-4-13 RECOIL STARTER, STARTER PULLEY AND SPACER

1) Install spacer and starter pulley to the flywheel.

M6 × 25mm bolt and washer ····· 3 pcs.

2) Install recoil starter. Make sure the recoil knob is pointing the right direction.

M6 × 12mm bolt and washer ····· 4 pcs.

6-4-14 CYLINDER BAFFLE

A clamp is fastened together on the air cleaner side of the cylinder baffle.

M6 × 16mm tapping bolt ····· 3 pcs.

M6 × 12mm flange bolt ····· 1 pc.

M6 × 8mm flange bolt ····· 1 pc.

6-4-15 MUFFLER

1) Replace muffler gasket with a new one.

2) Install muffler and muffler bracket. First temporary tighten nuts and bolts on the muffler and the bracket. Then tighten the nuts on the muffler and the bolts on the bracket.

M8 brass nut and spring washer ····· 2 pcs.

M8 × 16mm bolt and spring washer ····· 7 pcs.

6-4-16 SPEED CONTROL LEVER AND GOVERNOR LEVER

- 1) Install governor lever to governor shaft with adjusting plate being temporary tightened.
M6 nut and spring washer ······ 1 pc.
M4 × 8mm screw and spring washer ······ 1 pc.
- 2) Install governor control lever, washer (fiber) and cover to the crankcase in this sequence.
M6 × 8mm flange bolt ······ 1 pc.
- 3) Hook governor spring to the governor lever and speed control lever.

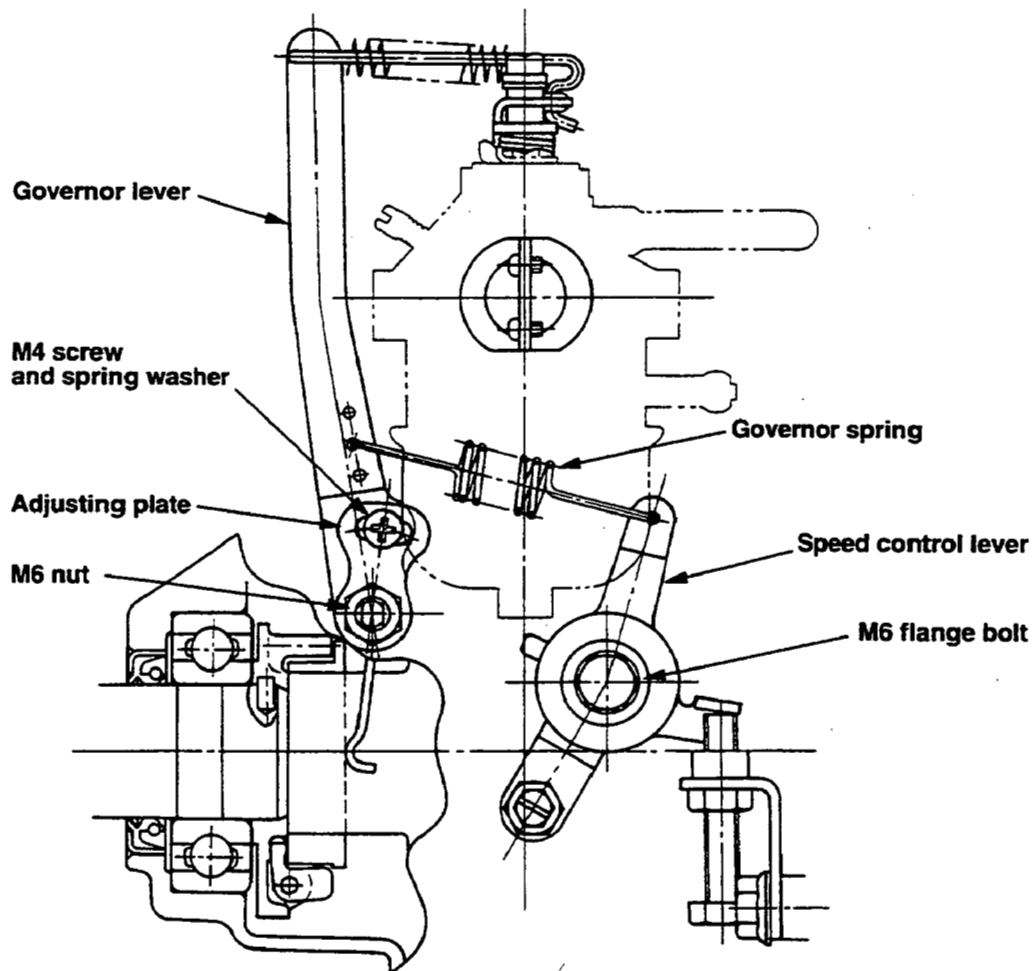

Fig. 6-8

6-4-17 CARBURETOR AND AIR CLEANER

- 1) Install packing and insulator to the cylinder. Replace packing with a new one.
- 2) Connect governor lever and throttle lever on the carburetor by governor rod and rod spring. And then install carburetor together with air cleaner base plate.
M6 self lock nut 2 pcs.
- 3) Install air cleaner bracket.
M6 × 12mm bolt and washer 3 pcs.

6-4-18 GOVERNOR ADJUSTMENT

Refer to section "7-2 Governor Adjustment"

6-4-19 WIRING

- 1) Connect wire from stop switch and primary wire from ignition coil. Clamp wire to cylinder baffle.
- 2) Connect spark plug cap to high tension cord then plug it to spark plug.

— End of the reassembly —

6-5 BREAK-IN OPERATION

An engine that has been completely overhauled by being fitted with a new piston, rings and crankshaft assembly should be thoroughly BREAK-IN before being put back into service.

Good bearing surfaces and running clearances between the various parts can only be established by operating the engine under reduced speed and loads for a short period of time.

While the engine is being tested, check for oil leaks.

Make final carburetor adjustment and regulate the engine operating speed.

Steps	Load	Engine Speed	Time
1	No load	2500 rpm	10 min
2	No load	3000 rpm	10 min
3	No load	3600 rpm	10 min
4	1.5 Hp or 40% Load	3600 rpm	30 min
5	3.0 Hp or 75% Load	3600 rpm	60 min

Table 6-1

NOTE : Use 25 : 1 Oil fuel mix for break-in period.

7. GOVERNOR

7-1 CONSTRUCTION AND OPERATION

A centrifugal flyweight type governor is used. The governor plate, governor sleeve and governor yoke are installed in the crankcase, and lubricated by the oil mixed fuel.

As the engine speed fluctuates, flyweights on the governor plate, rotating together with the crankshaft, changes its opening angle and moves the governor sleeve, which in turn rotates the governor shaft through the governor yoke. The governor lever is connected to the extending part of the governor shaft and this governor lever is connected to the carburetor throttle lever through the governor rod at the other end ; thus the throttle valve is opened or closed and engine speed and output are controlled.

When the crankshaft speed increases, all the relevant members move in the direction indicated by ← marks and the carburetor throttle valve closes, reducing the fuel supply and consequently reducing the speed and output. When the crankshaft speed decreases, the same members move in the direction indicated by → marks and the carburetor throttle valve opens, increasing the fuel supply and consequently recovering the failing speed and output.

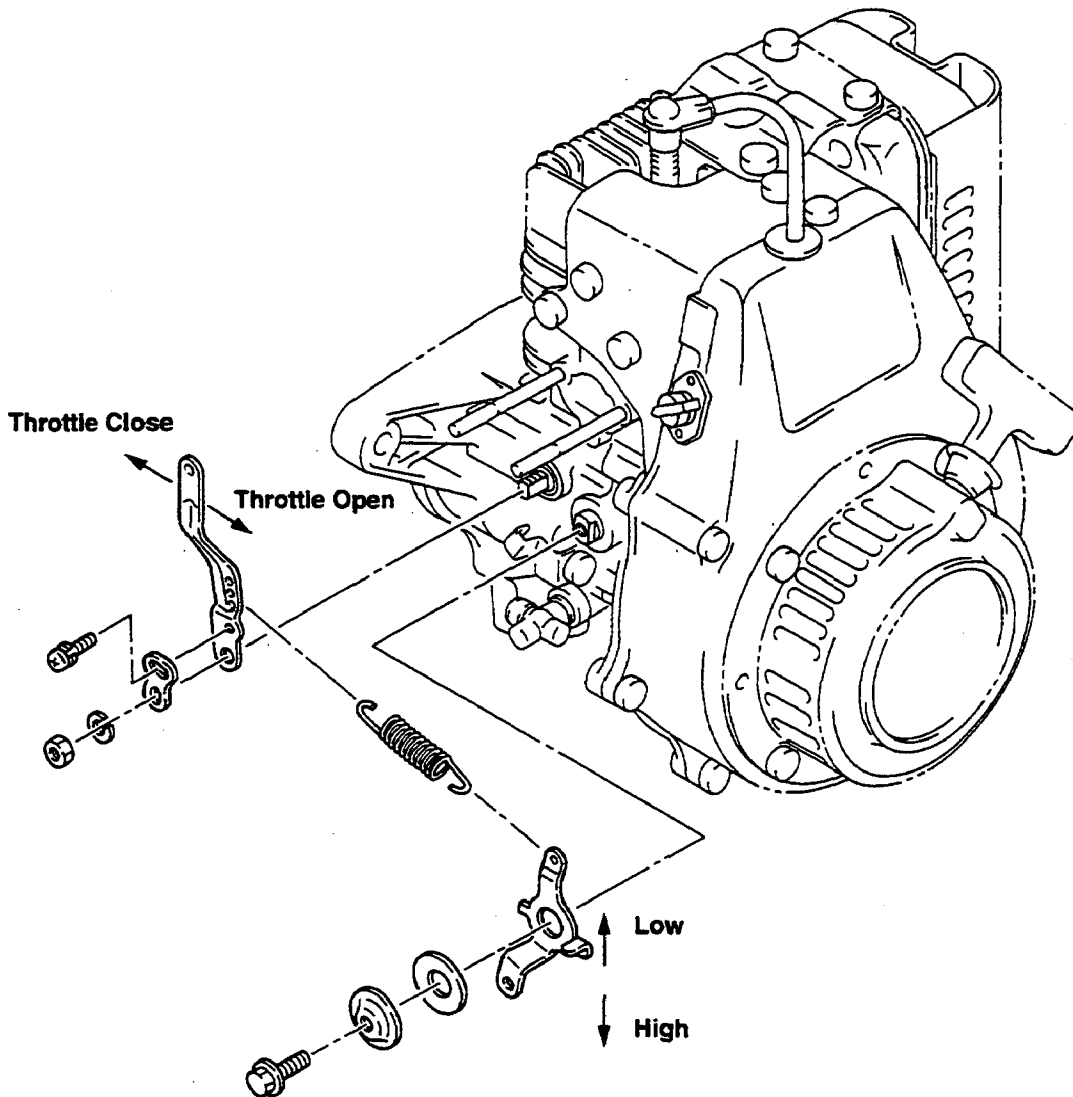

Fig. 7-1

7-2 GOVERNOR ADJUSTMENT

The governor system should be adjusted at reassembly by the following procedures.

- 1) Connect governor rod and rod spring to carburetor throttle lever and governor lever, then install governor lever to governor shaft.

NOTE : Never tighten the set screw for the adjusting plate at this time, and do not fix adjusting plate, governor lever and governor shaft.

- 2) Connect governor lever and control lever with governor spring, and install control lever to crankcase. And the governor adjustment is to be made in the following sequence:

- a) Attach the governor lever on the governor shaft.
- b) To the governor shaft, fasten temporarily the adjusting plate with nut and spring washer.
- c) To the governor lever, fasten temporarily the adjusting plate with screw (1) and nut (2).
At this moment, the adjusting plate is free to move. (See Fig.7-2.)
- d) Push the adjusting plate clockwise.
(See Fig.7-3.)
- e) Set the governor lever at the high position and tighten the screw (1) and nut (2).
(See Fig.7-4.)

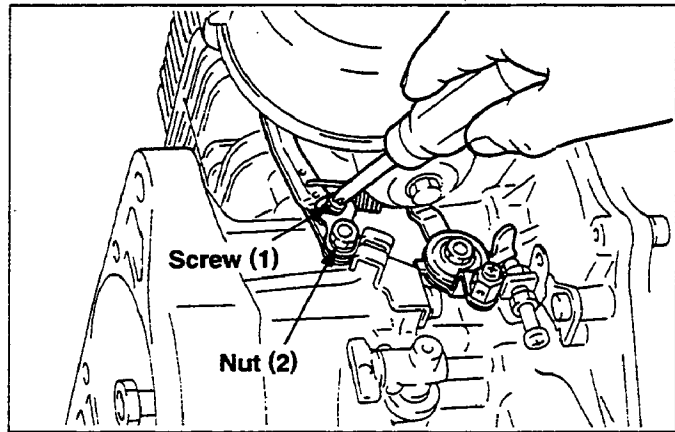

Fig. 7-2

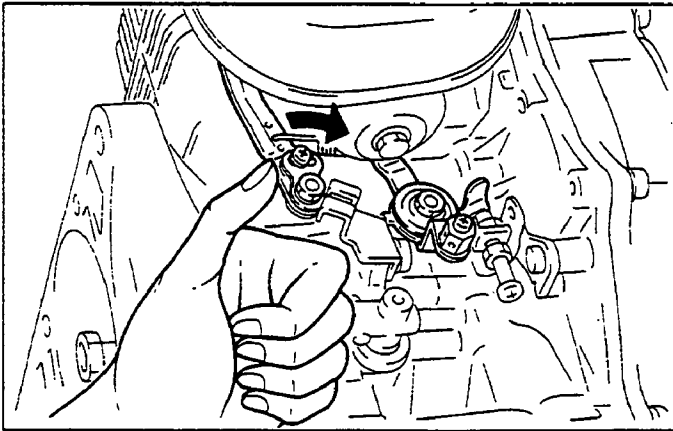

Fig. 7-3

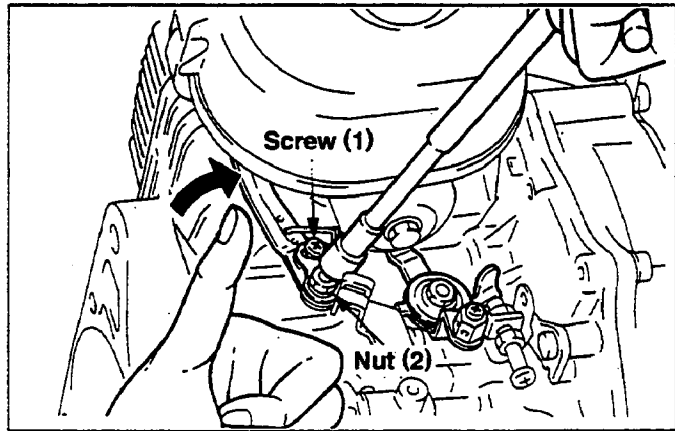

Fig. 7-4

7-3 HIGH SPEED ADJUSTMENT

7-3-1 WHEN NO TACHOMETER IS AVAILABLE

Unless required in the process of disassembling, do not remove governor control lever and / or other related parts from crankcase. If it is necessary to remove them, never turn high speed stop bolt on crankcase. (See Fig.7-5.)

7-3-2 WHEN A TACHOMETER IS AVAILABLE

- 1) Install control lever and other related parts.
- 2) By turning control lever with governor spring on it, gradually increase the engine speed up to specified engine speed.
- 3) Locate high speed stop bolt on the control lever and lock it so they it will stop control lever against the stopper plate.

Make sure that the governor spring is hooked in the same hole on the governor lever as original. There are 3 holes on the governor lever. Normally, hook governor spring in the center hole.

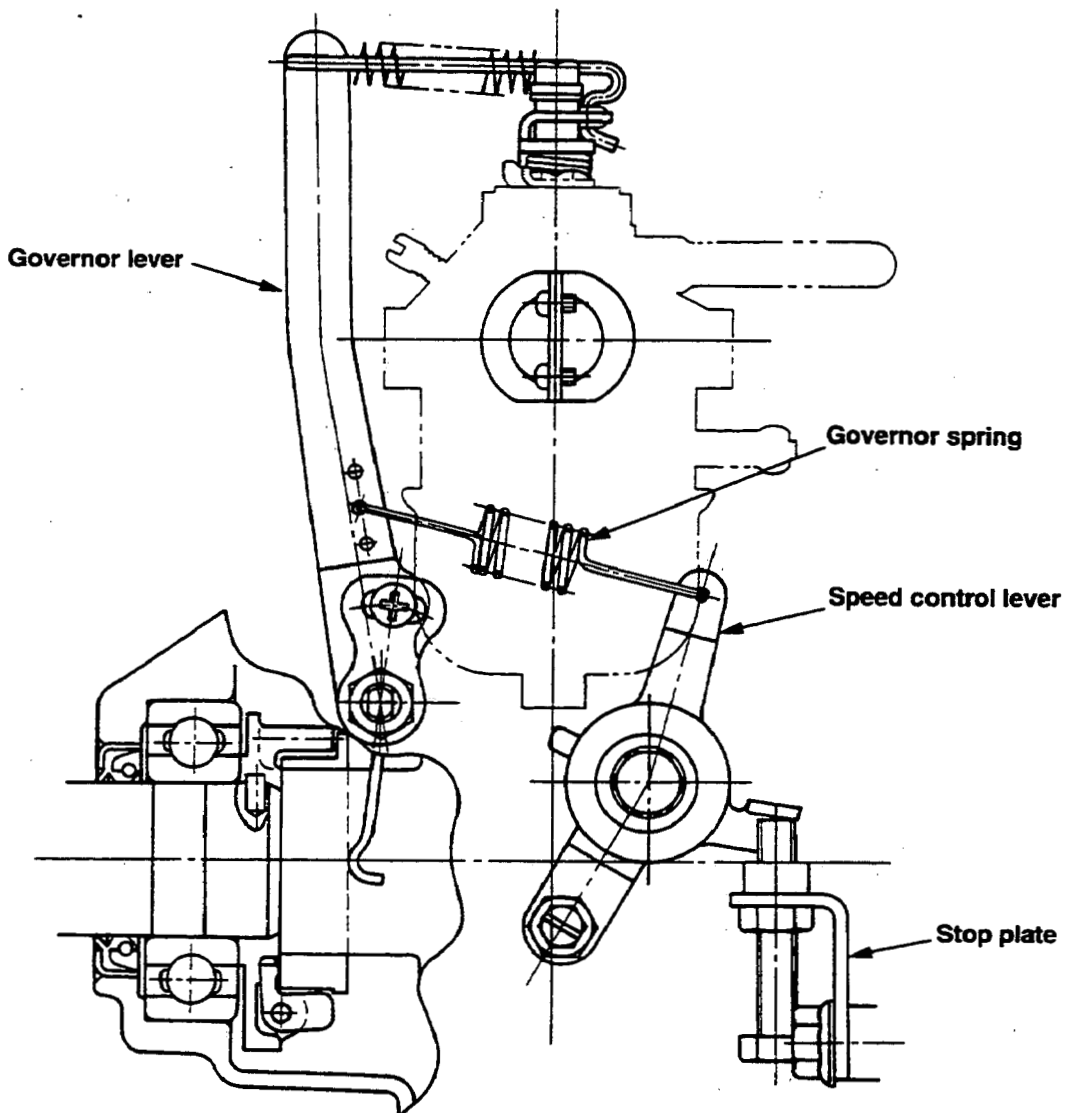

Fig. 7-5

8. MAGNETO

EC12 engine is equipped with a pointless Solid State Ignition system. This is a circuit breaker type ignition device which utilizes the power transistor as an element for controlling electric unit. This system is free from start-up failure due to dirty, burnt or oxidized point surfaces, low ignition efficiency because of moisture, rough breaker point surface and incorrect timing resulting from worn mechanical parts.

8-1 OPERATION OF THE IGNITION SYSTEM

This system is referred as T.C.I. (Transistor Controlled Ignition) system.

As illustrated in Fig.8-1., this is a simple system, consisting of a flywheel with magnetic fields, an ignition coil with built-in transistor, and lead wires to spark plug and stop switch.

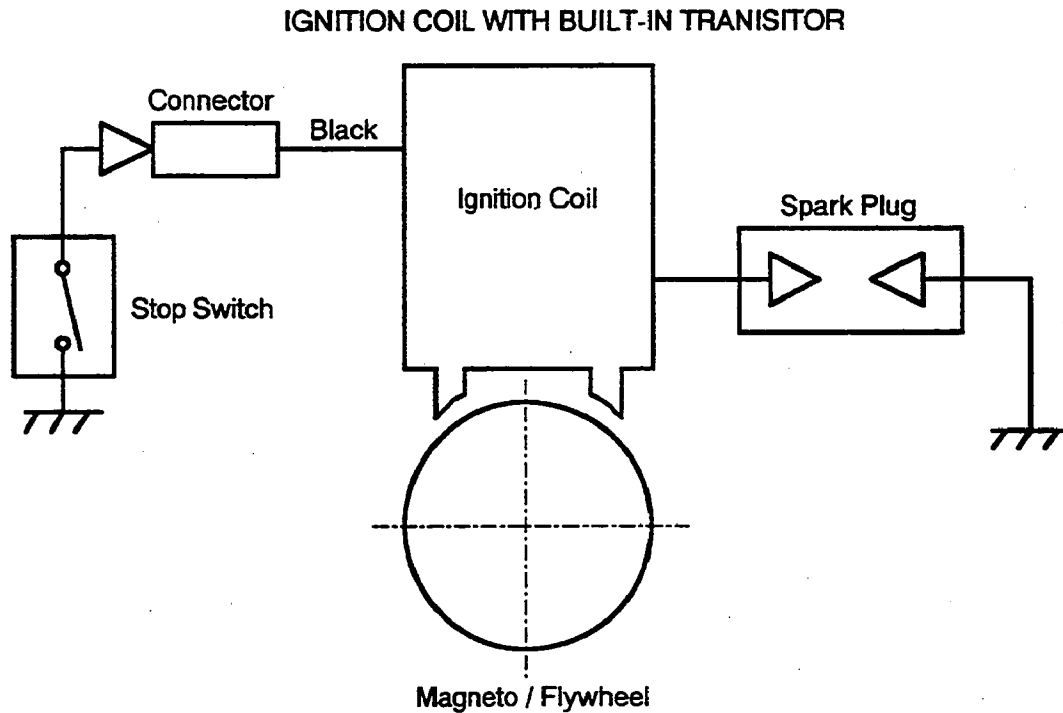

Fig. 8-1 WIRING DIAGRAM SOLID STATE IGNITION

8-1-1 PRINCIPLE OF THE OPERATION

- 1) Rotation of the flywheel generates a voltage on the primary side of the ignition device. By this voltage, electric current (I_1) flows and it charges condenser.
- 2) With further rotation of the flywheel, electric current (I_2), which is reversed of electric current (I_1), flows through power transistor base terminal (B). This actuates power transistor and results electric current (I_3) and (I_4) in signal transistor. The current (I_4) charges the condenser reversely as the current I_1 did.
- 3) With further move rotation of the flywheel, the current generated by primary coil starts to decrease as it passes its peak. Current (I_5) starts flowing because there is no electric potential difference in the C (collector) and E (emitter) Terminals of signal transistor. Current (I_5) flows into the gate (G) of SCR which induct SCR.
- 4) Current (I_2) turns into current (I_6) with induction of the SCR, this cuts off current I_3 abruptly. This current change causes high voltage on secondary coil which produces sparks at spark plug.

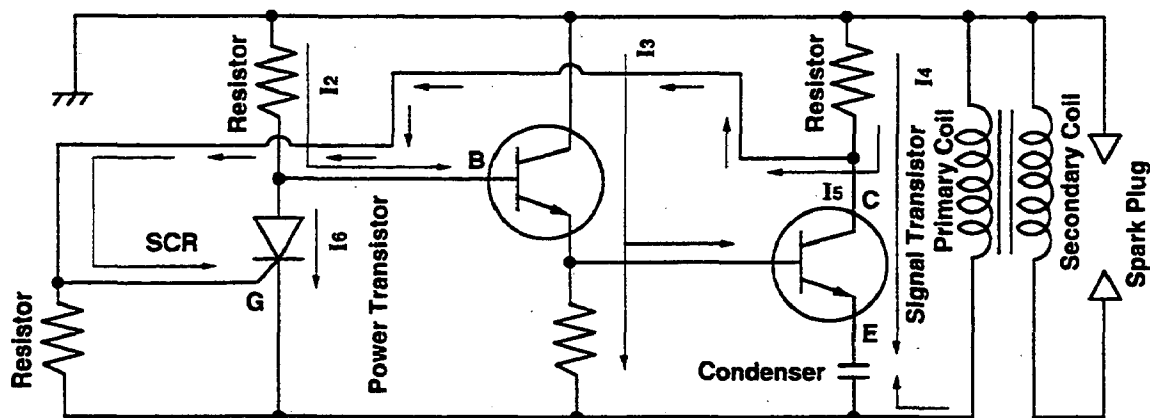

Fig. 8-2

8-2 IGNITION SYSTEM CHECK

In the event of malfunction of the ignition system, check the following first:

- Broken, frayed, loose or disconnected ignition wires.
- Faulty spark plug-wet, dirty, insulation broken or incorrect plug gap.

If difficulty is experienced in starting the engine or if engine misfires, the strength of the ignition spark should be checked:

Remove spark plug-then with the ignition cable connected to it, lay the spark plug on a convenient metal part of the engine so that the gap can be observed as you rotate the crankshaft several times by means of the recoil starter. If a good strong spark occurs, the ignition system can be eliminated as the source of trouble. If there is a weak spark or no spark at all, check the ignition system as follows:

- 1) Check to make sure that the external magnet, mounted on the flywheel is in a good condition.
- 2) Since the solid state ignition unit is self-contained, the only testing which can be performed is on the secondary coil resistance.

Using a good quality ohm-meter, check the secondary coil resistance between the plug terminal of the ignition lead and the engine stop switch wire.

This resistance reading should be approximately 10,000 to 12,000 ohms. If the resistance reading is infinite, this indicates open winding in the ignition unit, a loose or broken spark plug connector or a failed high tension lead.

If a very low reading is taken, the secondary coil is probably shorted. If, after testing, the ignition unit itself is determined to be faulty, then it will have to be replaced.

9. CARBURETOR

9-1 FLOAT CARBURETOR

9-1-1 OPERATION AND CONSTRUCTION

1) FLOAT SYSTEM

The float chamber is located below the carburetor body and, with a float and a needle valve, maintains a constant fuel level during engine operation. (See Fig.9-2.)

The fuel flows from the fuel tank into the float chamber through needle valve. When the fuel rises to a specific level, the float rises, and when its buoyancy and fuel pressure are balanced, the needle valve closes to shut off the fuel, thereby keeping the fuel at the predetermined level.

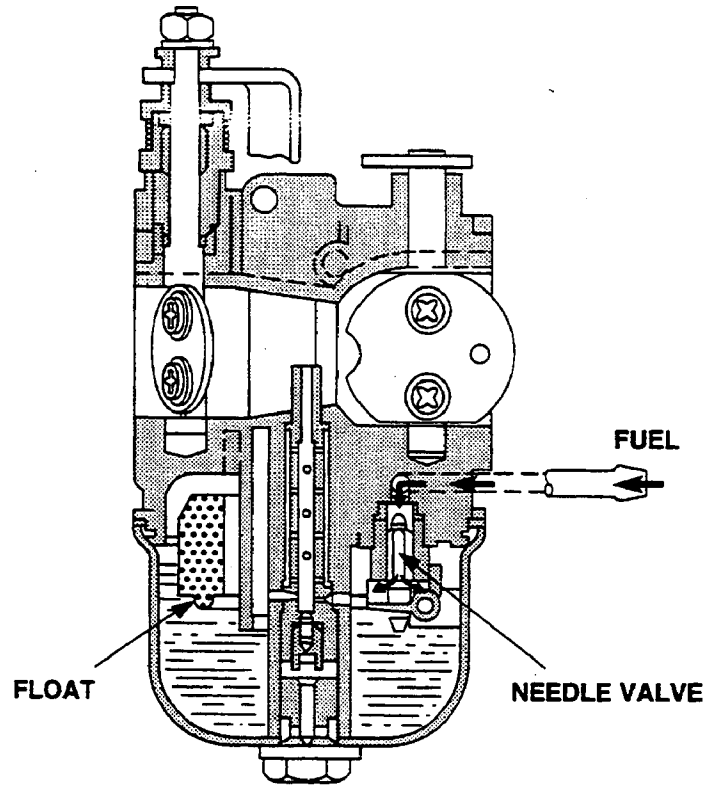

Fig. 9-1

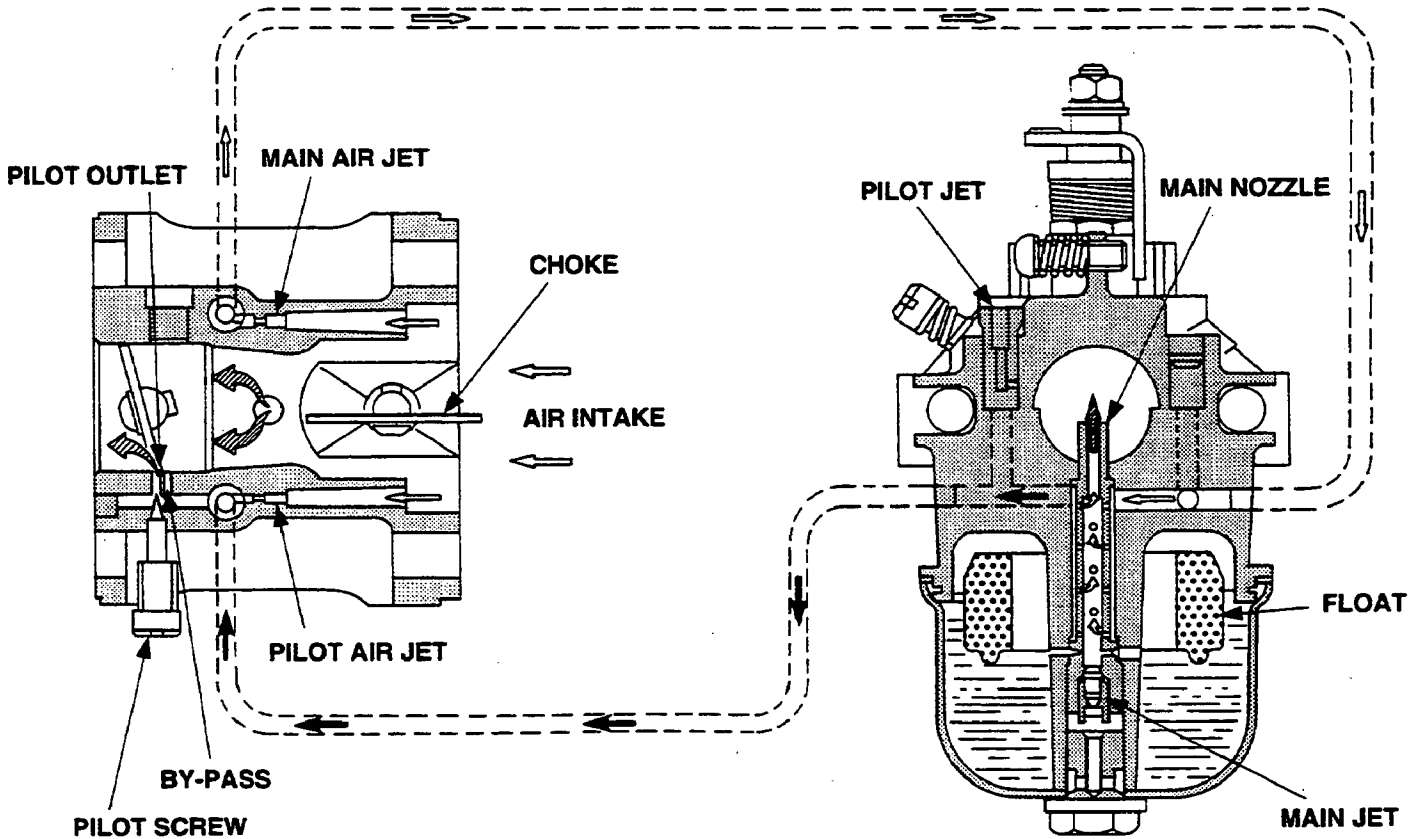

Fig. 9-2

2) PILOT SYSTEM

The pilot system feeds the fuel to the engine during idling and low-speed operation.

The fuel is fed through the main jet to the pilot jet, where it is metered and mixed with the air metered by the pilot air jet.

The fuel-air mixture is fed to the engine through the pilot outlet and the bypass.

At idling speed, the fuel is mainly fed from the pilot outlet.

3) MAIN SYSTEM

The main system feeds the fuel to the engine at medium and high-speed operation.

The fuel is metered by the main jet and fed to the main nozzle. The air metered by the main air jet is mixed with the fuel through the bleed holes in the main nozzle, and the mixture is atomized out of the main bore. It is mixed again with the air taken through the air cleaner into an optimum fuel-air mixture, which is supplied to the engine.

4) CHOKE

The choke is used for easy starting when the engine is cold. When the starter is operated with a closed choke, the negative pressure applied to the main nozzle increases and draws more fuel accordingly thus starting up the engine more easily.

9-1-2 DISASSEMBLY AND REASSEMBLY

A part from mechanical failures, most of the carburetor troubles are caused by an incorrect mixing ratio, which may arise mainly due to a clogged up air or fuel passage in the jets, or fuel level variations.

In order to assure proper flow of air and fuel, the carburetor must be kept clean at all times.

The carburetor disassembly and reassembly procedures are as follows : (See Fig.9-3.)

1) THROTTLE SYSTEM

- a) Remove the phillips screw (1) and throttle valve (2), and pull out the throttle shaft (3).
- b) The spring (4) can be taken out by removing the throttle stop screw (5).

* Be careful not to damage the throttle valve ends.

2) CHOKE SYSTEM

- a) Remove the Phillips screw (6) and choke valve (7), and pull out the choke shaft (8).
- b) When reassembling the choke shaft, make sure that the cutout in the choke valve faces the main air jet.

3) MAIN SYSTEM

- a) Remove the bolt (9) and take out the float chamber body (10).
- b) From the body remove the main nozzle (11) and then remove the main jet (12) from the main nozzle (11).
- c) Reassembly

- a) Fasten the main jet securely to the body. Otherwise, the fuel may become too rich and cause engine malfunction.

- b) The bolt tightening torque is 5 ft • lb (70kgf-cm). Be sure to set the gasket (13) and washer (14) for chamber (10).

4) FLOAT SYSTEM

- a) Pull out the float pin (15) and remove the float (16) then the clip (17) and needle valve (18).

CAUTION :

When cleaning the jets, use neither a drill nor a wire (because of possible damage to the orifice which will adversely affect fuel flow). Be sure to use compressed air to blow them clean.

- b) When removing the needle valve and float, gently tap on the reverse side using the rod more slender than the float pin and remove, since the float pin is calked to the carburetor body.

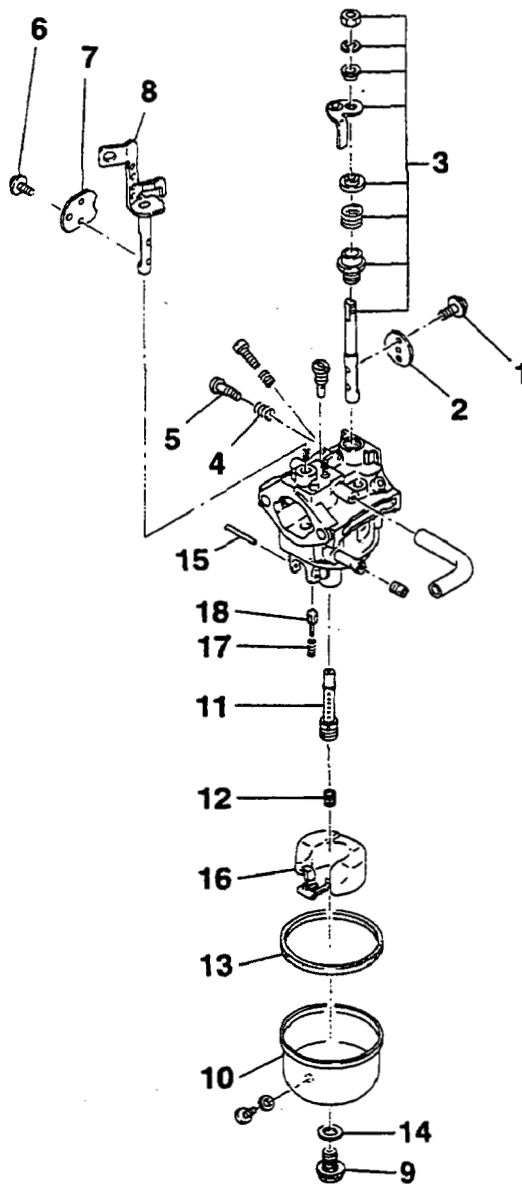

Fig. 9-3

9-2 DIAPHRAGM CARBURETOR

9-2-1 OPERATION AND CONSTRUCTION

1) PUMP

The diaphragm of the fuel pump is moved by pressure fluctuations in the engine crankcase. When it moves towards the engine, the inlet valve (E) of the pump opens and the outlet valve (A) shuts, and the pump sucks in fuel. When the diaphragm swings back, the inlet valve (E) closes and the fuel is forced out of the outlet valve (A).

A compensating chamber (W), situated between the inlet and the outlet valves cushions the oscillations of the fuel flowing past. The diaphragm of the chamber springs upwards towards the atmosphere fuel pressure builds up, and contracts again when the pressure drops.

After the pump, the fuel flows through the fine filter (F).

This traps residual particles of dirt, but is not a substitute for the large-area filter, which must be fitted in the fuel flow before the carburetor.

2) PRESSURE REGULATOR

A diaphragm pressure regulator ensures, almost independently of the pump pressure, a constant vacuum before the jet systems.

If the vacuum in the carburetor inlet pipe is transmitted to the pressure regulator via the jets, it moves the regulator lever (R) via the diaphragm (M), against a spring and opens the feed valve (N). An even flow of fuel then passes through the valve into the regulator and through the jets into the carburetor port. The diaphragm (M), the regulator lever (R) and the feed valve (N) constantly adjust to any given flow quantity.

3) HIGH SPEED OPERATION

If full power is required from the engine, the throttle valve and choke are fully opened.

The vacuum in the carburetor sucks fuel into the main system via main mixture screw (H) and the non-return valve (V), and through the idling system via idle mixture screw (L), the idling outlet drilling (LA) and the bypass drillings (BP).

The fuel flow can be altered by opening and closing main mixture screw and idle mixture screw.

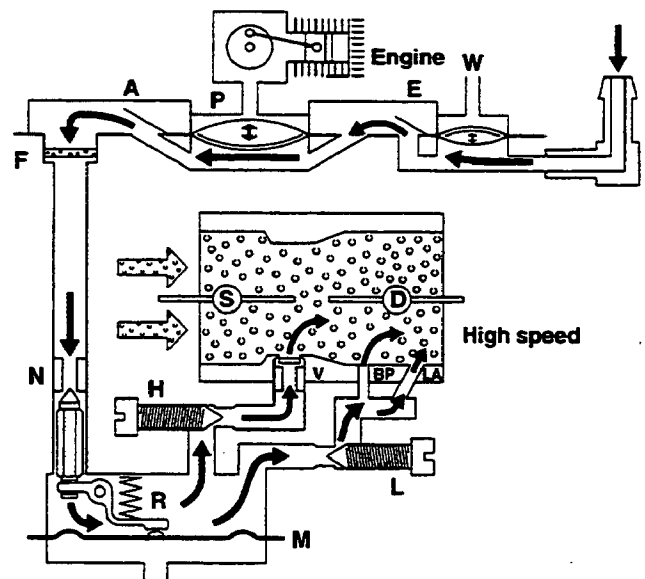

Fig. 9-4

4) MID-RANGE OPERATION

If only reduced engine output is required and the throttle valve is accordingly partially closed, a vacuum sufficient to suck fuel is present only in the space between the throttle valve and the engine. The fuel now only flows through the idling system. As a result, the non-return valve (V) in the main system closes, thus preventing air from entering the pressure regulator, where it could impede the fuel flow.

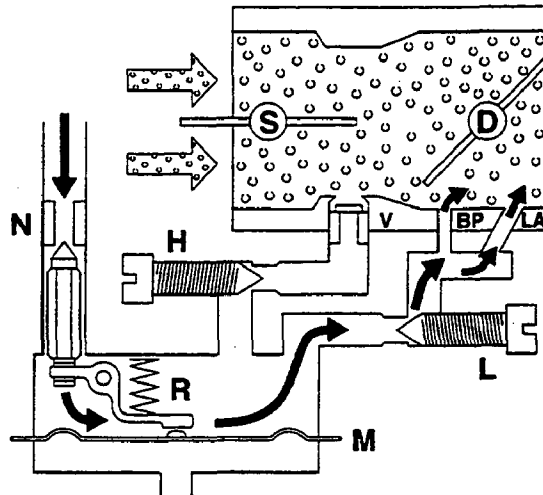

Fig. 9-5

5) IDLING OPERATION

When the engine is idling, the throttle valve is so far closed that the vacuum between the valve and the engine only acts on the idling outlet drilling (LA). While fuel is being sucked out of the idling outlet drilling (LA), air is entering the bypass drilling (BP), which mixes with the fuel coming out.

The idling speed is set with the stop screw (LAS) and the matching fuel quantity with idle mixture screw (L).

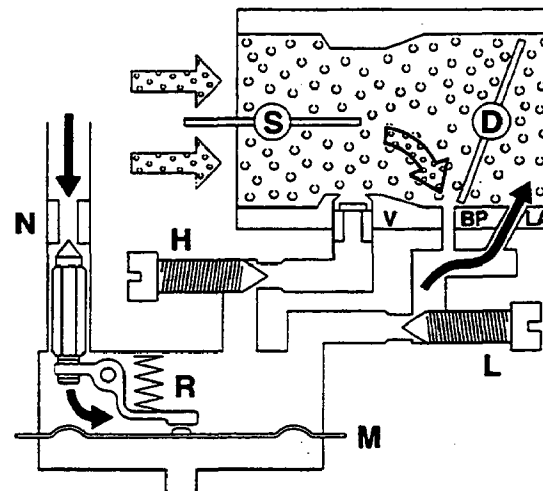

Fig. 9-6

6) STARTING

To start the engine, the choke is closed, with the throttle valve (D) roughly half-open.

Each attempt to start the engine produces a vacuum in the carburetor port, which draws fuel through both jet systems.

When starting a hot or cold engine, the carburetor must first be filled with fuel, as air and fuel vapour must be flushed out of the carburetor systems. Several attempts at starting-usually four, are necessary before the first firing occurs.

The choke must then be opened and the next attempt will start the engine running.

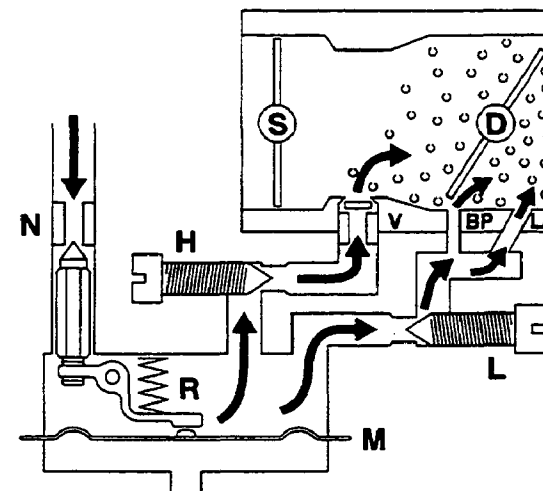

Fig. 9-7

9-2-2 DISASSEMBLY

A part from mechanical failures, most of the carburetor troubles are caused by an incorrect mixing ratio, which may arise mainly due to a clogged up air or fuel passage in the jets, or fuel level variations. In order to assure proper flow of air and fuel, the carburetor must be kept clean at all times. The carburetor disassembly and reassembly procedures are as follows : (See Fig.9-8.)

1) FUEL PUMP

- a) Remove the screw (1) and pump cover (2).
- b) Remove pump gasket (3) and diaphragm (4).
- c) Inspect diaphragm (4), replace if diaphragm shows any signs of wear and curing.
- d) Remove strainer (5).

2) METERING DIAPHRAGM

- a) Remove the screws (6) and metering chamber cover (7).
- b) Remove metering diaphragm (8) and the gasket (9).
- c) Inspect metering diaphragm (8) for dirt and foreign matter.

3) INLET NEEDLE VALVE

- a) Remove the screw (10) of metering lever (11).
- b) Remove metering lever (11), pin (12) and lever spring (13).
- c) Remove inlet needle valve (14).
- d) Inspect inlet needle valve (14). Rubber tip should not be deformed where it contacts the seat.

4) MIXTURE SCREW

- a) Remove idle (15) and main (16) mixture screw and washer (17).
- b) Remove the spring (18).
- c) Inspect each screw (15, 16) for damage, especially the needle points which should have no deformation of the tapered surfaces.

5) THROTTLE AND CHOKE

- a) Remove the E-ring (19) and the screw (20) and throttle valve (21), and pull out the throttle shaft (22).
- b) Remove the screw (23) and the choke valve (24), and pull out the choke shaft (25).

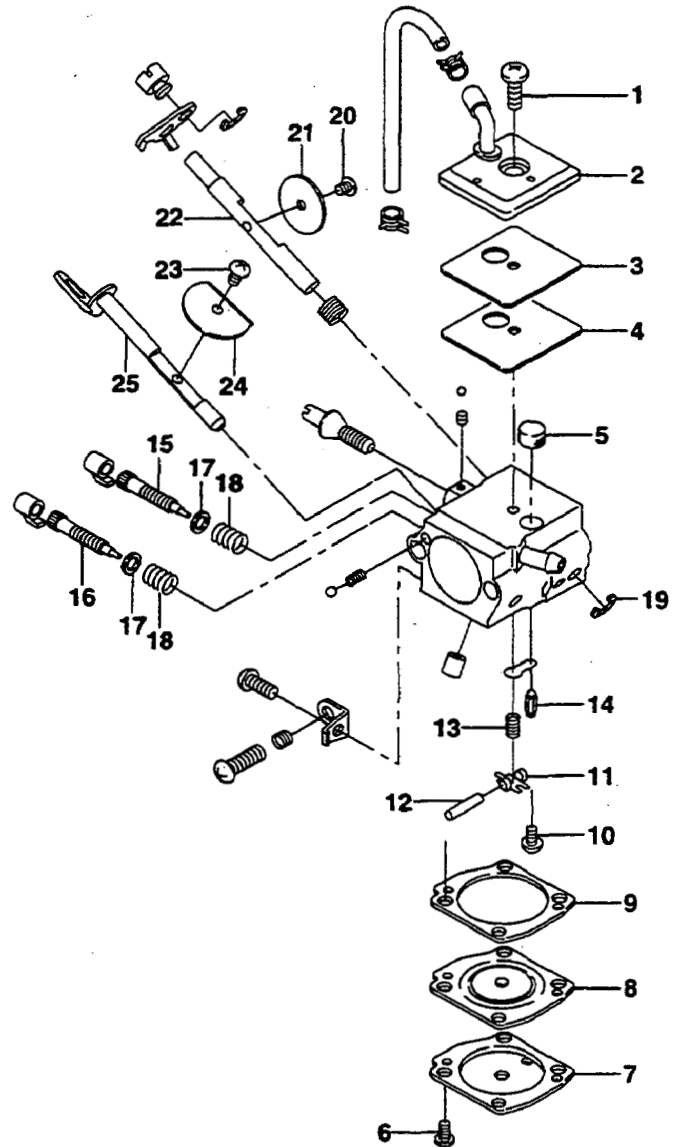

Fig. 9-8

9-2-3 Reassembly and Adjustment

Replace all worn with new ones. Make sure to clean all parts before reassembly.

1) MIXTURE SCREW

Install idle and main mixture screws.

- a) For the nominal setting, tighten the screws fully and then turn back counterclockwise at the following turns ;

Idle mixture screw

2 turns

Main mixture screw

1 and 1/2 turns

In accordance with the actual operation and fuel consumption condition, adjust the screws as necessary.

Turning back for the nominal setting

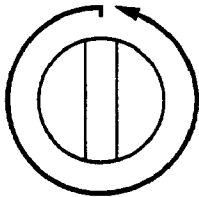

One turn

Turning direction for air fuel ratio adjustment

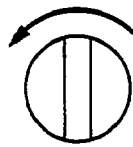

Richer

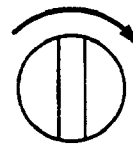

Leaner

Fig. 9-9

2) INLET NEEDLE VALVE

- a) Inspect the metering lever and the pin.

Assemble the lever onto the pin and rotate the pin.

The lever should be a free fit on the pin and should not stick.

- b) Install the inlet needle valve, metering spring, metering lever, pin and retaining screw.

- c) The free end of the metering lever should be 0 to 0.3 mm (0 to 0.012") below the metering gasket flange of carburetor body. (Fig. 9-10).

If the metering lever is too high, push down on the free end of the lever, then carefully push down on the inlet needle. If the metering lever is too low, pry up carefully on the free end of the lever. (Fig. 9-11)

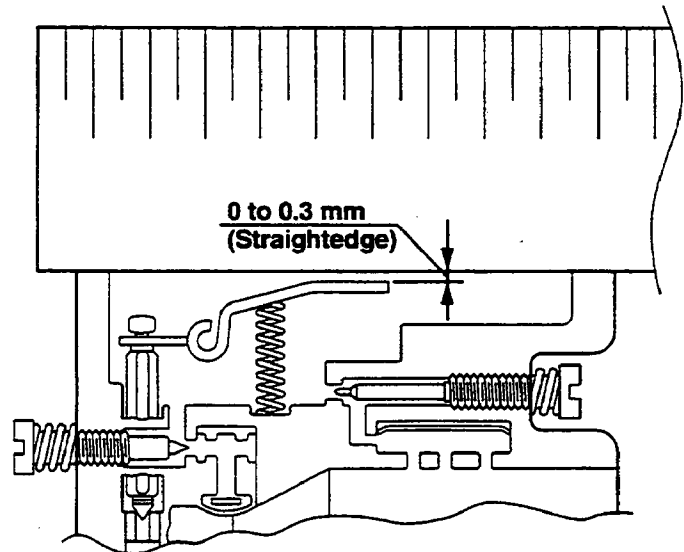
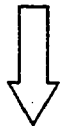
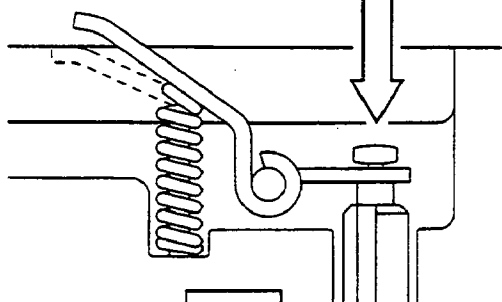
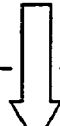

Fig. 9-10

Push down here



Then push down needle here



High

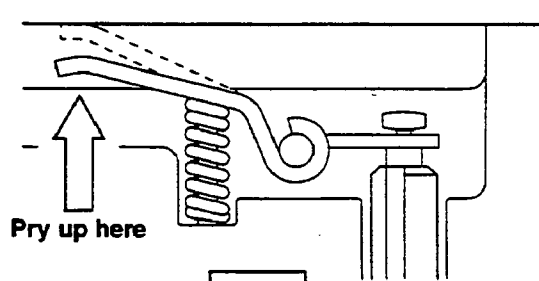

Pry up here

Low

Fig. 9-11

10. OIL INJECTION SYSTEM

10-1 SEPARATE OIL INJECTION / FUEL SYSTEM

(1) Oil flow

(2) Mixture ratio

Idle	19 : 1 @ 1600 rpm
Load	25 to 30 : 1 @ 3800 rpm

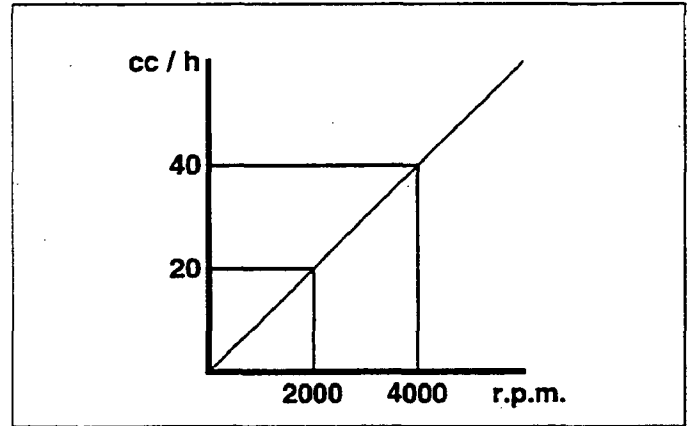

Fig. 10-1

10-2 BASIC STRUCTURE OF THE SEPARATE OIL ONJECTION / FUEL SYSTEM

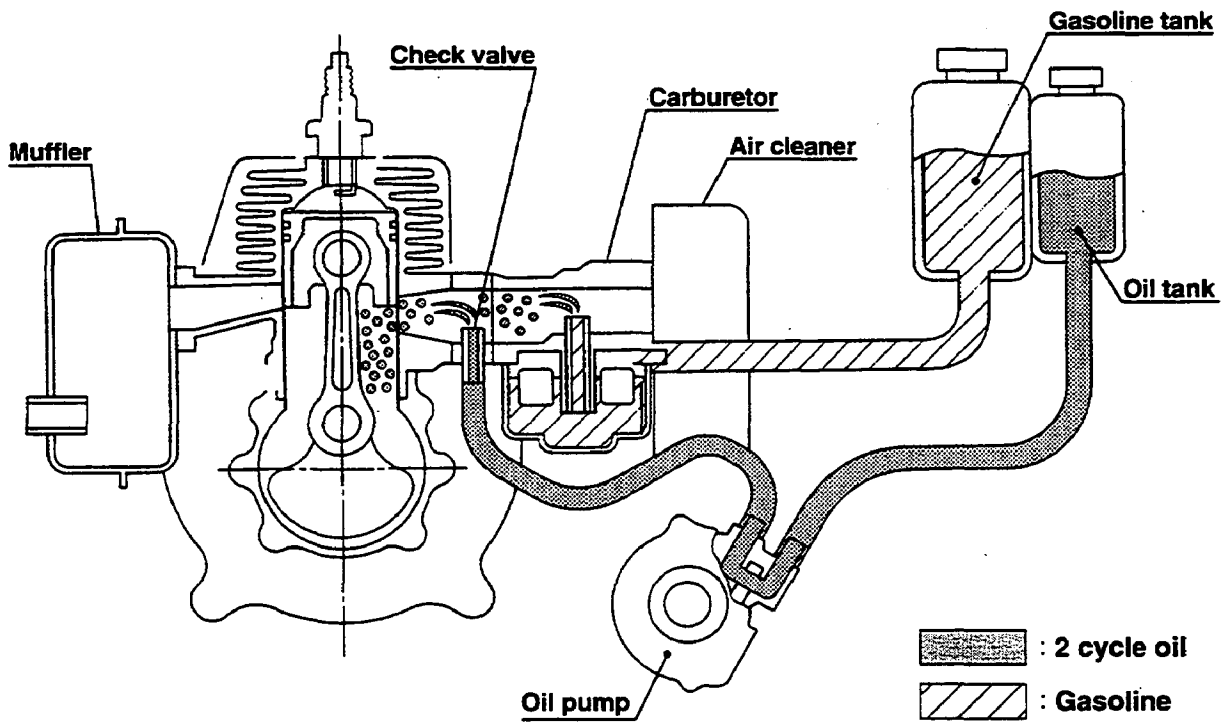

Fig. 10-2

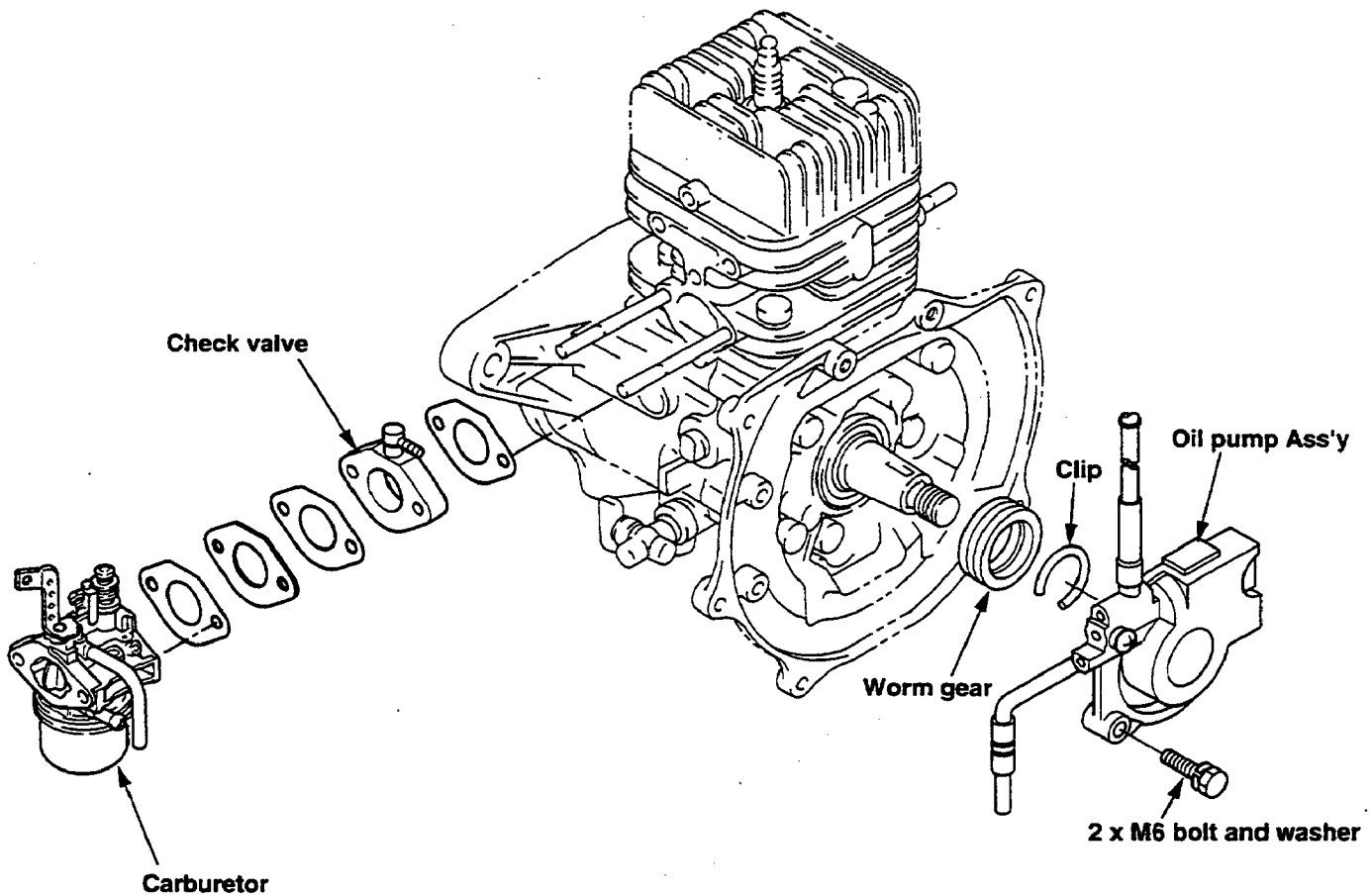

Fig. 10-3

10-3 OIL PUMP OPERATION / FUNCTION

10-3-1 OIL PUMP (1M64-01) OPERATING PRINCIPLE

- (1) The crankshaft turns which rotates the worm gear. The plunger which directly goes to the worm rotates at 1/17th of engine speed.
- (2) The plunger will be pushed down to the pins by the spring. Then it moves to left and right with a rotating motion due to the configuration of the edge of lead.
- (3) The sub plunger will be stabilized into the plug by the spring via E ring. By above (2) stroke, pumping will occur.

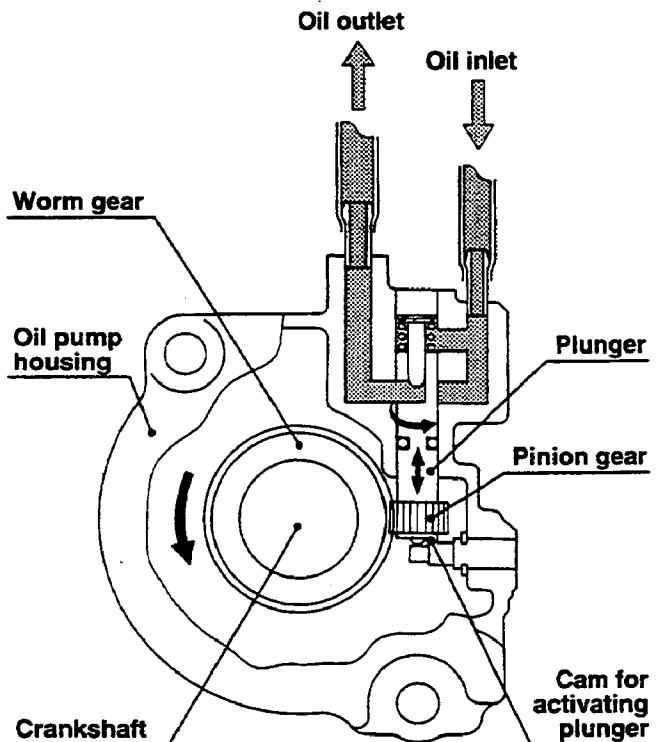
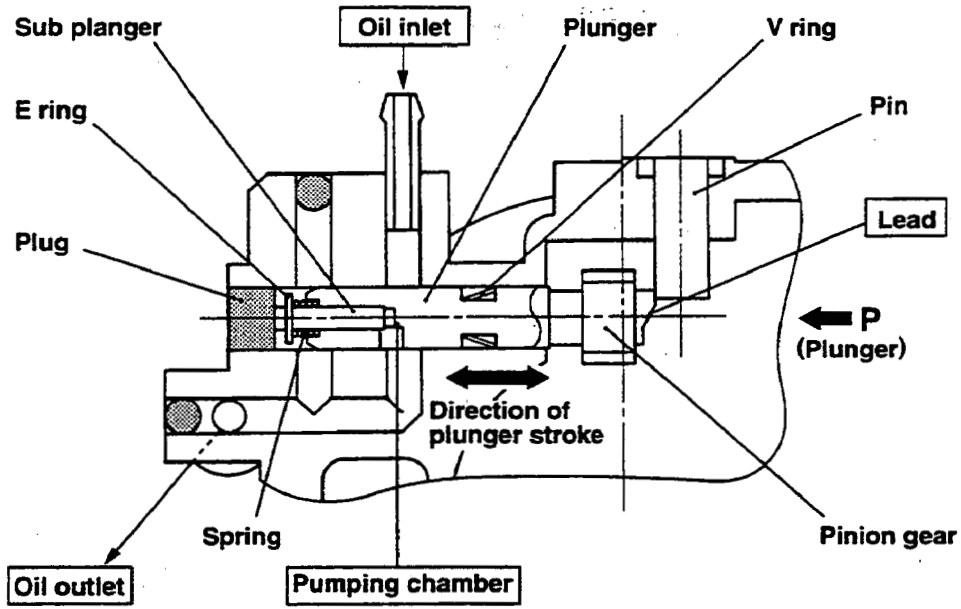

Fig. 10-4



Detail A

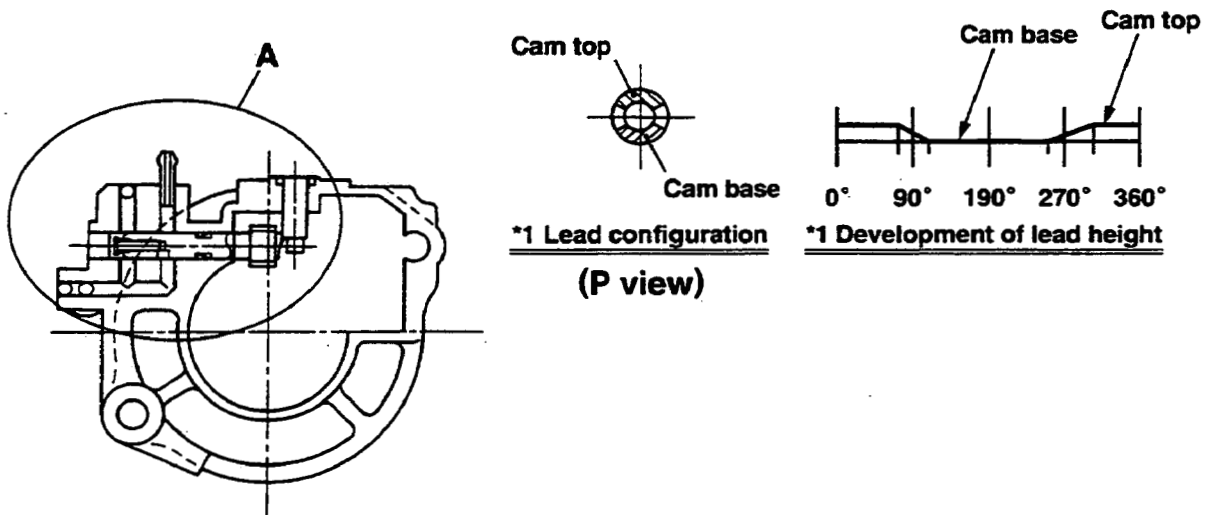



Fig. 10-5

10-3-2 OIL INTAKE AND DISCHARGE CYCLE AT OIL PUMP

The plunger rotates 360 degree with a cycle. (Shared  area means oil.)

(1) Intake

The plunger remains in the closed position.
The plunger strokes to the right.
The volume of oil chamber is expanded.

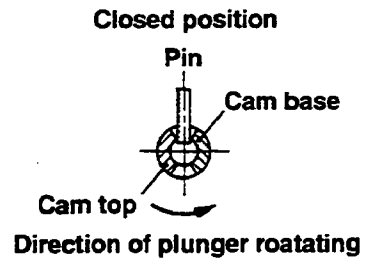
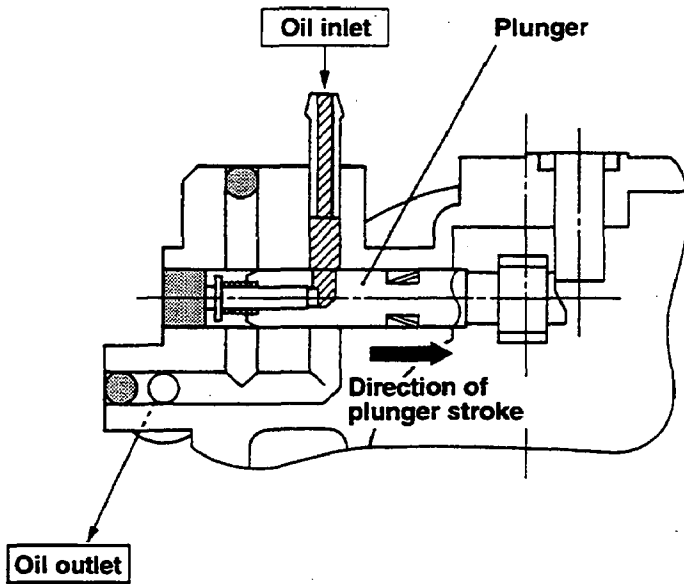

Fig. 10-6

(2) Discharge

The plunger is raised to the open position by the pin.
The plunger strokes to the left.
The volume of oil chamber is decreased.

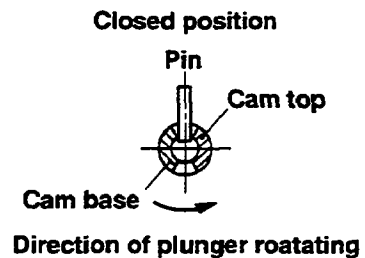
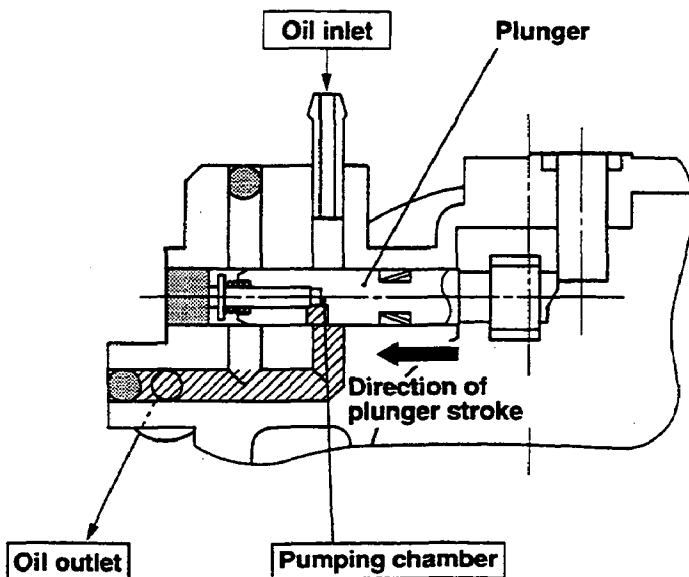

Fig. 10-7

10-3-3 CHECK VALVE AND FLOATING SWITCH

(1) Check valve

This valve is composed of a ball and body seat.

The ball is stabilized by a spring. The ball overrides the spring at time the pressure exceeds its setting load. When engine stops, this prevents air from entering into oil tube due to vacuum.

Also this prevents oil from leaking when long storage.

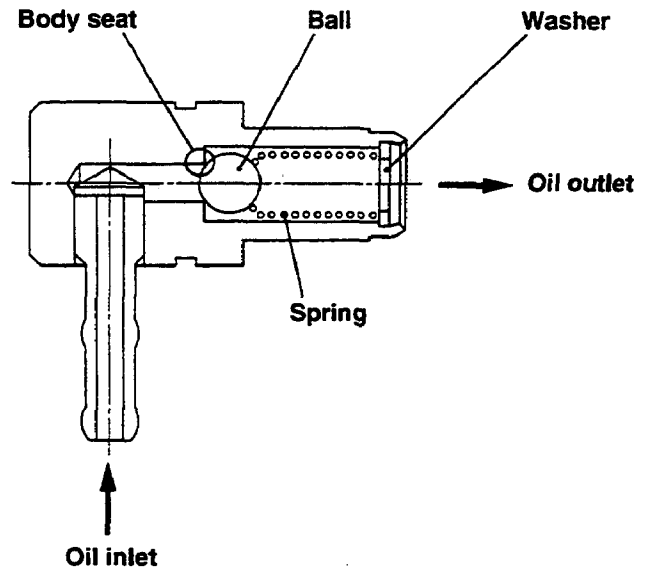
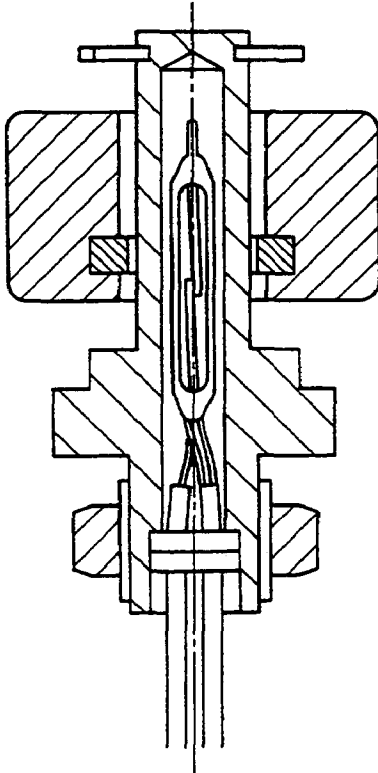

Fig. 10-8

(2) Floating switch

This floating switch is located in the oil tank.

1. Structure of floating switch



This illustration shows on position

2. Operating principle

(1) Float located above

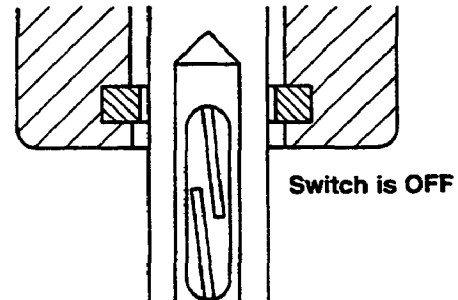

Switch is OFF

(2) Float located below limit

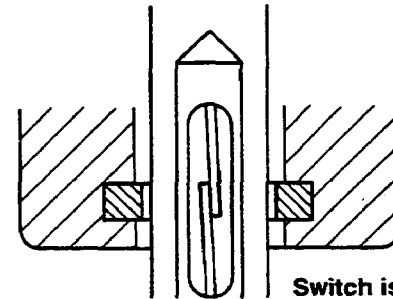

Switch is ON due to exciting

Fig. 10-9

11. RECOIL STARTER

When repairing the recoil starter, disassemble and reassemble according to the following procedures.

Tools : Needle nose pliers screw driver.

11-1 DISASSEMBLY

- (1) Remove the recoil starter from the engine.
- (2) Pull the starter knob and pull out the starter rope about 12 in. (30cm) to line up the notch on the reel with the outlet hole for the starter rope.

Hold the reel with your thumb and pull the starter rope inside the starter case with a screw driver. (See Fig.11-1.)

While rewinding the reel, control the rotation by holding the starter rope the notch on the reel and pressing the reel with your thumb.

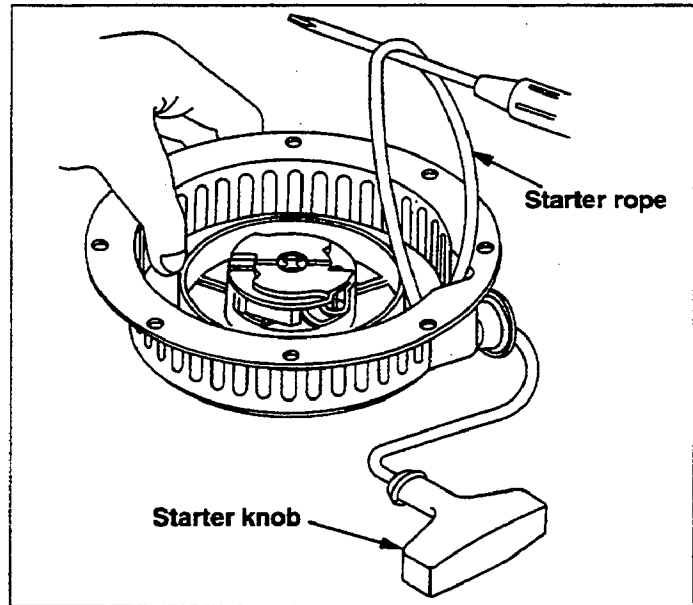

Fig. 11-1

- (3) Remove the parts in the following order.
 1. Center screw
 2. Ratchet guide
 3. Friction plate
 4. Ratchet
 5. Return spring
 6. Reel
- (4) Untie the starter rope from the knob and remove.

CAUTION :

Take out the reel slowly turning it slightly towards the left and right to remove the spring from the hook. Do not remove the reel quickly or the spring may escape from the starter case.

Note : If power spring escapes from housing refer to section 11-2.

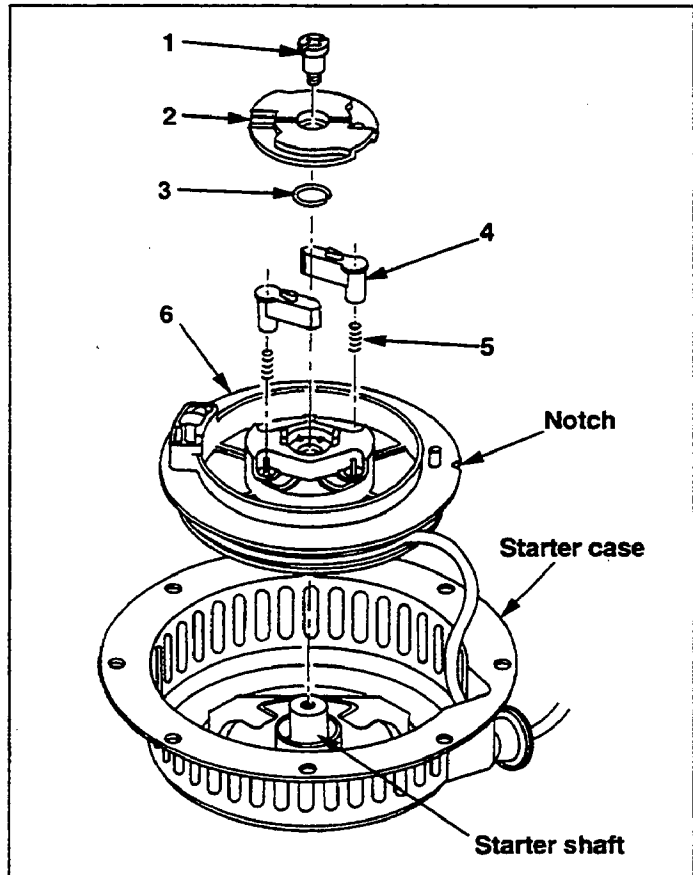

Fig. 11-2

11-2 REASSEMBLY

- (1) Put the starter rope through the starter knob and tie it as shown in Fig.11-3-1. (Tie the rope tightly for safety sake.)

Put the opposite side of the rope through starter case and reel. Tie it securely as shown in Fig.11-3-2. and put the knot in the reel completely.

Then apply grease a little to starter shaft and power spring.

- (2) Check that the spring is securely set in the reel. Adjust the position of the inner end of the spring to 0.04" - 0.08" (1-2mm) from the reel bush so that it hooks on the hook in the starter case securely.

The shape of the power spring inner end can be adjusted with a plier if necessary.

- (3) Prior to installing the reel in the starter case, wind the starter rope in the reel for 2.5 turns in the arrowhead direction as shown in Fig.11-5. Then let the rope out of the reel from the reel notch. Line up the hook on the starter case with the inner end of the spring and install the reel in the starter case. Check that the inner end of the spring is securely hooked on the starter case hook.

- (4) Hold the starter rope as shown in Fig.11-5. and turn the reel 4 to 5 times in the arrowhead direction.

Firmly press the reel not to allow reverse turning and pull the starter knob to let the starter rope out of the starter case.

Return the knob slowly to let the starter rope rewind in the reel.

- (5) Reassemble the parts in reverse order of disassembly.

Apply a small amount of lock-tight to set screw and torque it.

TIGHTENING TORQUE	
3.4 ~ 5.4	N·m
35 ~ 55	kgf·cm
25.2 ~ 39.6	ft·lb

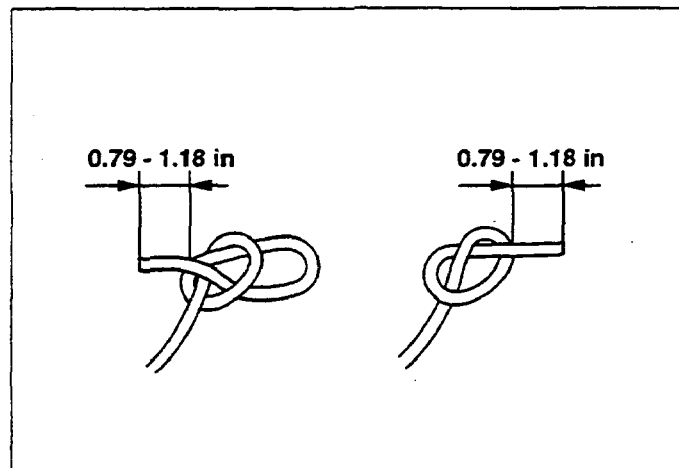

Fig. 11-3-1

Fig. 11-3-2

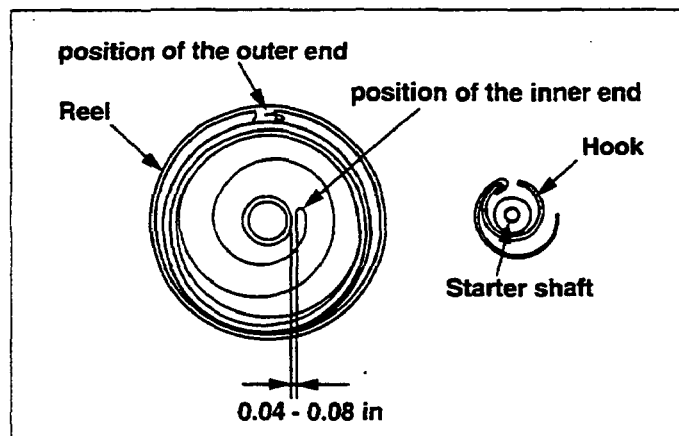

Fig. 11-4

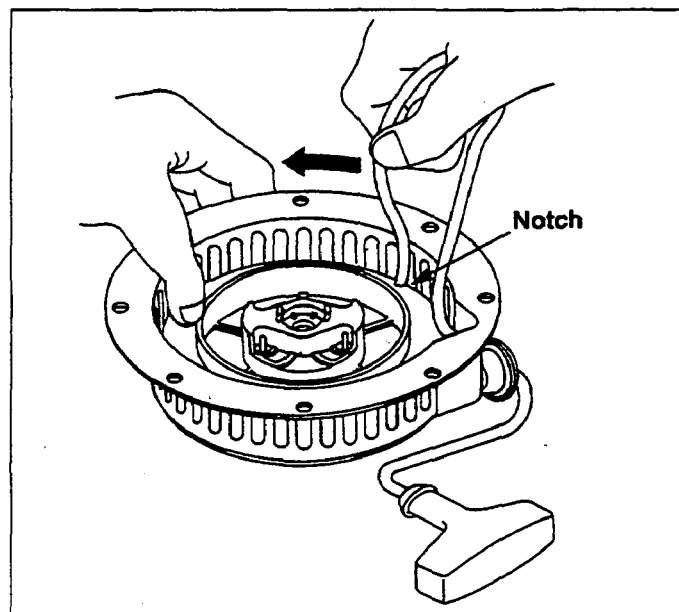

Fig. 11-5

11-3 CHECK AFTER REASSEMBLY

- (1) Test the operation of the recoil starter to see if the rope recoils satisfactorily and if the ratchets project and retract properly.
- (2) Pull the starter knob all the way and check following.
 - If there is starter rope left in the groove of the reel, the power spring is overloaded. Rewind the reel once or twice. (See Fig.11-1.)
 - If the starter rope return is weak or stops before it completely returns to original position, apply grease or mobile oil to rotating and sliding parts.
If it does not cure the problem, wind the starter rope once or twice.
(After doing so check that the power spring is not over loaded, by preceding paragraphs method.)
 - If the starter rope does not retract, the power spring is not hooked. Reassemble the recoil starter from the first step.

11-4 WHEN POWER SPRING ESCAPES FROM HOUSING

Make a spring holder for the power spring-form a ring a little smaller than power spring housing I.D. from a piece of 12 or 16 ga. soft iron wire and twist the ends together. Wind the power spring inside the wire ring-start with the outer loop of the spring and wind in a counter clockwise direction.

Place the spring assembly over the recess in the housing, so that the hook in the outer loop of the spring is over the tension tab on the reel. (Fig.11-4.) Carefully press the spring out of the wire ring (Spring holder) and into the recess in the housing.

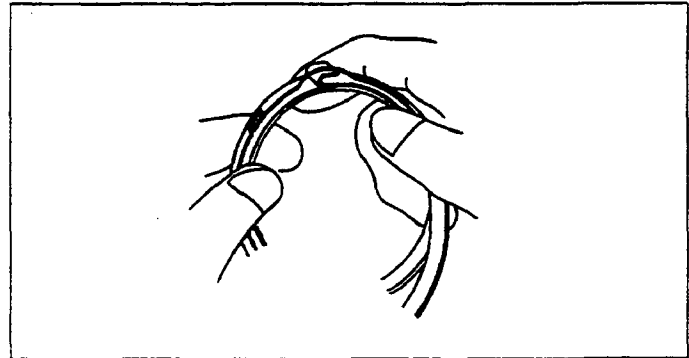

Fig. 11-6

12. TROUBLESHOOTING

For a gasoline engine to start and run satisfactorily, the following three requirements must be met:

- 1) A proper fuel-air mixture is supplied to the combustion chamber.
- 2) Appropriate compression in the cylinder.
- 3) Good spark at correct time to ignite the mixture.

If all the three requirements are not met simultaneously, an engine cannot be started. There are also other factors such as heavy load at starting or too long an exhaust pipe causing a high back pressure, which contribute to hard starting.

The most common causes of engine troubles are given below.

12-1 STARTING DIFFICULTIES

	Cause	Remedy	Preventive measure
Little or No Spark	Defects in spark plug	<ol style="list-style-type: none"> 1) If contaminated, wash in gasoline, remove foreign matters and dry. 2) If spark plug is broken or lost insulation, replace plug. 3) Adjust spark gap to .025 (.65mm) 	<ol style="list-style-type: none"> 1) Use spark plugs of specified heat range. Do not use poor grade oil. Clean air cleaner and avoid dust entry. 2) Do not hit or bend the center electrode of the spark plug at adjusting or the insulator may get damaged.
	Defects in high-tension cord	If cord is burnt or damaged, replace the ignition coil unit.	
	Defects in magneto	<ol style="list-style-type: none"> 1) If wire or insulation is broken, replace magneto. 2) If magnetism is weak, re-magnetize (at the magneto maker) or replace flywheel. 	
	Other defects in electric system	<ol style="list-style-type: none"> 1) If switch is faulty (short circuit), replace or repair. 2) If primary wire is grounded to the engine body, insulate it with insulating tape. 	
Little or No Compression	Gas leak through head gasket or other parts	<ol style="list-style-type: none"> 1) If head gasket is defective, replace. 2) If head bolts are loose, tighten. 3) If spark plug is loose, tighten. 4) If spark plug is defective, replace. 	
	Defects in piston assembly	<ol style="list-style-type: none"> 1) If piston is worn, replace. 2) If cylinder is worn, re-bore and use oversize piston and piston ring. 3) If piston rings are worn, replace. 4) If piston rings are stuck, clean or replace rings. 	<ol style="list-style-type: none"> 1) Keep air cleaner always clean. 2) Do not use poor grade oil.
No Fuel Supply	Defects in fuel tank system	<ol style="list-style-type: none"> 1) Clean clogged tank outlet. 2) Clean clogged fuel strainer. 3) If incorrect fuel is poured into tank or water is mixed, drain tank completely and fill it with correct fuel. 4) When fuel pipe is locked with air, discharge air. 	<ol style="list-style-type: none"> 1) Be sure to use a filter when adding fuel. 2) Use mixture (gasoline 25 to 50 : 1) as fuel.
	Defects in carburetor	<ol style="list-style-type: none"> 1) If clogged with dust, clean. 2) If defective, replace. Clean jets and other orifices, if they are clogged. 	

	Cause	Remedy	Preventive measure
Excessive Fuel		1) Start engine with fully open choke valve and half open throttle valve. 2) Remove drain plug from crankcase, and close fuel cock, repeat starting operation several times to discharge excess fuel.	1) Never close choke valve when engine is warm. 2) When stopping the engine, run it at slow speed for a while. This practice not only favorably affects next starting, but also improves engine life. 3) Clogged air-cleaner results in too rich airfuel mixture. Clean it thoroughly.
	Defects in carburetor	If fuel overflows, check needle valve seat for wear. Replace, if necessary.	Be careful clogged carburetor.
Too much resistance at starting	Excess load	1) If tension of transmission belt is too tight, reduce tension. 2) If load is still too heavy, install a clutch.	
	Piston or Connecting Rod seized	1) If piston seizes, repair or replace. 2) If connecting rod large end or small end seize, replace.	1) Do not use poor grade oil. 2) Use fuel of proper mixing ratio.

12-2 SLOW-SPEED out of order

Most defects listed as causes for starting difficulty are also causes for faulty slow-speed operating.

12-3 OVERHEATING and KNOCKING

- 1) If carbon deposits have accumulated in the combustion chamber, remove them.
- 2) If the heat range of the spark plug is too cool, replace it with correct one, i.e. NGK BM6A or CHAMPION CJ8.
- 3) If the air-fuel mixture is too lean, clean jets and other passages in the carburetor. Clean the air cleaner also.
- 4) If the load is in excess, reduce it below the specified continuous load.

12-4 POWER DROP

- 1) If the cylinder, piston or piston rings are worn, replace them or re-bore the cylinder and fit oversize piston and piston rings. Replace or clean piston rings if they are stuck in the grooves.
- 2) If the carburetor is out of order, re-adjust or clean it.
- 3) If the spark plug is faulty (contamination, gas leakage or faulty insulation), clean it or replace it.
- 4) If combustion gas leaks through the head gasket, re-tighten the clamping screws. If the gasket is faulty, replace it.
- 5) If the magneto is faulty, replace it.
- 6) If the air cleaner is clogged, clean it.
- 7) If the fuel system is clogged, clean it.
- 8) If the oil seals at the crankshaft are worn and the compressed gas is leaking, replace them.

12-5 EXCESSIVE FUEL CONSUMPTION

- 1) If air-fuel mixture is too rich, clean jets and passages in carburetor.
- 2) If the throttle shaft of carburetor is worn, replace throttle shaft. (carburetor)
- 3) If fuel is leaking, re-tighten screws or replace faulty part.
- 4) If the engine suffers power drop accompanied with excessive fuel consumption, trouble-shoot by following step 7-4.

13. INSTALLATION

Engine life, ease of maintenance and inspection, frequency of check and repairs, and operating costs all depend on the way in which the engine is installed. Carefully observe the following instructions for installing the engine.

13-1 INSTALLING

When mounting the engine, carefully examine its position, the method of connecting it to a machine, the foundation, and the method of supporting the engine.

Particularly, when determining its mounting position, make sure that fuel can easily be supplied and checked, the spark plug can easily be checked and the air cleaner can easily be serviced.

13-2 VENTILATION

Fresh air is necessary for cooling the engine and burning the fuel.

In case the engine is operated under a hood or in a small room, temperature rise in the engine room can cause vapor lock, loss of power, piston seizure, shorter engine life, etc., making it impossible to operate the engine properly. It is necessary, therefore, to provide a duct or baffle to guide cooling air to the engine to prevent recirculation of the hot air used for engine cooling, and temperature rise of the machine.

Keep the engine room temperature below 50°C (122°F) even in the hottest period of the year.

13-3 EXHAUST GAS DISCHARGE

Exhaust gas is noxious. When operating the engine indoors, be sure to discharge the exhaust gas outdoors. If a long exhaust pipe is used in such a case, the internal resistance increases causing loss of engine power. Thus the inside diameter of the pipe must be increased in proportion to the exhaust pipe length.

Exhaust pipe : Less than 3m (9.8 ft) long, pipe inside diameter 30mm (1.18 in)

Less than 5.45m (18 ft) long, pipe inside diameter 33mm (1.30 in)

13-4 POWER TRANSMISSION TO DRIVEN MACHINES

13-4-1 BELT DRIVE

Take the following notes into consideration.

- * V-belts are preferable to flat belts.
- * The driving shaft of the engine must be parallel to the driven shaft of the machine.
- * The driving pulley of the engine must be in line with the driven pulley of the machine.
- * Install the engine pulley as close to the engine as possible.
- * If possible, span the belt horizontally.
- * Disengage the load when starting the engine.

If no clutch is used, use a belt tension pulley or the like.

13-4-2 FLEXIBLE COUPLING

When using a flexible coupling, runout and misalignment between the driven shaft and the engine shaft must be minimized. Runout and misalignment tolerance are specified by the coupling manufacturer.

13-5 FUEL SYSTEM

When remote mounting fuel tank, set the fuel head (height difference between fuel tank bottom and carburetor fuel inlet) to 5 - 50cm (2 - 20 in). Not enough fuel head causes a poor fuel supply and the excessive head induces overflow of carburetors.

To avoid air lock and vapor lock, carefully examine diameter and curvature of fuel hose, heat transfer and leak at joints.

Make the hose length as short as possible. Fuel filter must be installed in the fuel system.

14. CHECKS AND CORRECTIONS

After disassembling and cleaning the engine parts, check them, and if necessary, correct them according to the correction table.

The correction table applies whenever engines are repaired. Its contents should be thoroughly understood by those who undertake the repairing.

Its specifications must be abided by to effect correct maintenance.

Following are the terms employed in the correction table.

1) **CORRECTION**

All operations performed on the engine parts for the purpose of improving or recovering the engine performance, consisting of repairs, readjustments, and replacements.

2) **STANDARD SIZE**

The design dimension of the part without the tolerance.

3) **CORRECTION TOLERANCE**

The tolerance on the re-finished part dimension or on the readjusted dimension.

4) **CORRECTION LIMIT**

The limit on the part and adjustment, beyond which any dimensional and functional changes, due to wear, burn, and other causes will adversely affect the normal engine performance.

5) **USE LIMIT**

The limit, beyond which the part is no longer usable, due to defects in function or strength.

14-1 CORRECTION TABLE

Unit : mm (in)

ITEM		STANDARD SIZE	CORRECTION	
			TOLERANCE	LIMIT
Flatness of cylinder head		Less Than 0.1 (0.004)		0.2 (0.008)
Cylinder	Bore	STD $\phi 54$ (2.1260)	+0.020 $\left(\begin{smallmatrix} +0.0008 \\ 0 \end{smallmatrix} \right)$	$\phi 54.15$ (2.1319)
		O.S $\phi 54.25$ (2.1358)	+0.020 $\left(\begin{smallmatrix} +0.0008 \\ 0 \end{smallmatrix} \right)$	$\phi 54.40$ (2.1417)
		O.S $\phi 54.50$ (2.1457)	+0.020 $\left(\begin{smallmatrix} +0.0008 \\ 0 \end{smallmatrix} \right)$	$\phi 54.65$ (2.1516)
	Roundness (After rebores)		0.01 (0.0004)	
	Cylindricity (After rebores)		0.015 (0.0006)	
Piston	Outside diameter	STD $\phi 53.96$ (2.1244)	$\begin{smallmatrix} 0 \\ -0.015 \end{smallmatrix} \left(\begin{smallmatrix} 0 \\ -0.0006 \end{smallmatrix} \right)$	$\phi 53.86$ (2.1205)
		O.S $\phi 54.21$ (2.1343)	$\begin{smallmatrix} 0 \\ -0.015 \end{smallmatrix} \left(\begin{smallmatrix} 0 \\ -0.0006 \end{smallmatrix} \right)$	$\phi 54.11$ (2.1303)
		O.S $\phi 54.46$ (2.1441)	$\begin{smallmatrix} 0 \\ -0.015 \end{smallmatrix} \left(\begin{smallmatrix} 0 \\ -0.0006 \end{smallmatrix} \right)$	$\phi 54.36$ (2.1402)
	Piston pin hole	$\phi 12$ (0.4724)	$\begin{smallmatrix} 0 \\ -0.011 \end{smallmatrix} \left(\begin{smallmatrix} 0 \\ -0.004 \end{smallmatrix} \right)$	$\phi 11.965$ (0.4711)
	Width of ring groove	TOP 1.59 (0.063) (MAX. WIDTH OF KEYSTONE)	+0.02 $\left(\begin{smallmatrix} +0.0008 \\ 0 \end{smallmatrix} \right)$	1.44 (0.057)
		SECOND 1.5 (0.059)	+0.06 $\left(\begin{smallmatrix} +0.002 \\ +0.04 \end{smallmatrix} \right)$ +0.04 $\left(\begin{smallmatrix} +0.002 \\ 0.016 \end{smallmatrix} \right)$	1.35 (0.053)
	Clearance between piston ring and piston groove	TOP, SECOND	0.05 - 0.1 (0.0002 - 0.004)	0.15 (0.0006)
	Clearance between piston and cylinder		0.040 - 0.074 (0.0002 - 0.004)	0.25 (0.0098)
Fit between piston and piston pin		0.008 $\left(\begin{smallmatrix} 0.0003 \\ 0.008 \end{smallmatrix} \right) \begin{smallmatrix} L \\ T \end{smallmatrix}$ 0.008 $\left(\begin{smallmatrix} 0.0003 \\ 0.0003 \end{smallmatrix} \right) \begin{smallmatrix} L \\ T \end{smallmatrix}$	0.06 L (0.0024) L	
Piston ring	Ring gap	0.1 - 0.25 (0.0039 - 0.0098)		1.5 (0.059)
	Ring width	1.5 (0.059)	-0.01 $\left(\begin{smallmatrix} -0.0004 \\ -0.03 \end{smallmatrix} \right)$ -0.03 $\left(\begin{smallmatrix} -0.0004 \\ -0.012 \end{smallmatrix} \right)$	-0.1 (0.0039)
Piston pin O.D.		$\phi 12$ (0.472)	-0.003 $\left(\begin{smallmatrix} -0.0001 \\ -0.008 \end{smallmatrix} \right)$ -0.008 $\left(\begin{smallmatrix} -0.0001 \\ -0.0003 \end{smallmatrix} \right)$	$\phi 11.97$ (0.471)
Crankshaft & Connecting rod	Large end I.D.	$\phi 24$ (0.945)	+0.009 $\left(\begin{smallmatrix} -0.0004 \\ 0 \end{smallmatrix} \right)$	0.055 (0.002)
	Clearance between rod large end I.D. and crank pin needle bearing		0.004 - 0.022 (0.0002 - 0.0009)	
	Small end I.D.	$\phi 16$ (0.630)	+0.011 $\left(\begin{smallmatrix} 0.0004 \\ 0 \end{smallmatrix} \right)$	$\phi 16.02$ (0.631)

ITEM	STANDARD SIZE	CORRECTION			
		TOLERANCE	LIMIT		
Crankshaft and Connecting rod	Clearance between small end I.D. and Piston pin needle bearing		0.003 - 0.023 (0.0001 - 0.0009)	0.055 (0.0022)	
	Large end side clearance		0.1 - 0.5 (0.004 - 0.020)	0.7 (0.028)	
	Parallelism and Twist between large end and small end bores	Parallelism		0.05 (0.002)	0.1 (0.004)
		Twist		0.1 (0.004)	0.3 (0.012)
	Large end small end I.D. roundness and cylindricity	Roundness		MAX. 0.004 (0.0002)	
		Cylindricity		MAX. 0.004 (0.0002)	
	Distance between large end and small end bore	94	+0.05 (0.002) -0.05 (0.002)	+0.25 (0.010) -0.25 (0.010)	
	Crankpin O.D.	φ 18	0 (0) -0.005 (-0.0002)	φ17.98 (0.708)	
	Crankpin O.D. Roundness and Cylindricity	Roundness		MAX. 0.005 (0.0002)	
		Cylindricity		MAX. 0.005 (0.0002)	
	Crankshaft journal O.D.	φ 25	+0.003 (+0.001) -0.006 (-0.002)	φ24.97 (0.983)	
Crankshaft end play		0 - 0.2 (0.008)	0.6 (0.024)		
Crankshaft deviation		0.05 (0.002)	0.12 (0.0047)		
Dia. of small end needle bearing	φ 2	0 (0) -0.002 (-0.00008)			
Electric Equipment	Spark plug	Champion CJ8 or NGK BM6A			
	Spark timing (before T.D.C.)	18° (Fixed)	± 2°	± 5°	
	Spark plug gap		0.6 - 0.7 (0.024 - 0.028)		
	Ignition coil air gap		0.3 - 0.5 (0.012 - 0.020)		

14-2 TORQUE SPECIFICATIONS

DESCRIPTION		TIGHTENING TORQUE		
		kgf · cm	N · m	ft · lb
Crankcase		90 - 100	8.8 - 9.8	6.5 - 7.2
Cylinder		180 - 220	17.6 - 21.5	13 - 16
Cylinder head		180 - 220	17.6 - 21.5	13 - 16
Flywheel		390 - 420	38 - 41	28 - 30
Spark plug	New spark	120 - 150	11.7 - 14.7	8.7 - 10.8
	Retightening	250 - 300	24.5 - 29.4	18 - 22
M6 Bolt and Nut		90	8.8	6.5
M8 Bolt and Nut		250	24.5	18
M10 Bolt and Nut		370	36.2	26.7

15. MAINTENANCE AND STORING

The following maintenance jobs apply when the engine is operated correctly under normal conditions. The indicated maintenance intervals are by no means guarantees for maintenance free operations during these intervals.

For example, if the engine is operated in extremely dusty conditions, the air cleaner should be cleaned every day instead of every 50 hours.

15-1 DAILY CHECKS and MAINTENANCE

Checks and Maintenance	Reasons for requiring them
Remove dust from whatever parts which accumulated dust.	The governor linkage is especially susceptible to dust.
Check external fuel leakage. If any, retighten the loose part or replace faulty part.	Danger of causing fire.
Check screw tightening. If any loose one is found, re-tighten.	Loose screws and nuts will cause vibration resulting in the engine damage.

15-2 EVERY 50 HOURS (10 DAYS) CHECK and MAINTENANCE

Checks and Maintenance	Reasons for requiring them
Clean air cleaner	Clogged air cleaner affects engine operation.
Check spark plug. If contaminated, wash in gasoline or polish with emery paper.	Output power is reduced and starting is made difficult.

15-3 EVERY 100 to 200 HOURS (MONTHLY) CHECKS and MAINTENANCE

Checks and Maintenance	Reasons for requiring them
Clean fuel strainer and fuel tank.	The carburetor will be clogged with dirt or dust causing bad starting or poor operation.

15-4 EVERY 500 to 600 HOURS (SEMIANNUAL) CHECKS and MAINTENANCE

Checks and Maintenance	Reasons for requiring them
Remove cylinder head and remove carbon deposit. Remove carbon deposit from exhaust port and muffler.	The engine output power drops.
Disassemble and clean carburetor.	The carburetor will be clogged causing bad starting or poor operation.

15-5 EVERY 1000 HOURS (YEARLY) CHECKS and MAINTENANCE

Checks and Maintenance	Reasons for requiring them
Perform overhaul, clean, correct or replace parts.	The engine output drops.
Change piston rings.	
Replace fuel hose once a year.	Rubber hoses may be hardened and cracked by the ozone in the air.

15-6 PREPARATION for LONG STORAGE

- 1) Perform the above 13-1 and 13-2 maintenance jobs.
- 2) Drain fuel from the fuel tank, carburetor float chamber and fuel lines.
- 3) To prevent rust in the cylinder bore, apply oil through the spark plug hole and turn the crankshaft for several turns by hand. Re-install the spark plug.
Turn the starting pulley by hand and leave it where the resistance is the greatest.
- 4) Clean the engine outside with oiled cloth.
- 5) Cover the engine and store in dry place.



Robin America, Inc.

940 Lively Blvd., Wood Dale, IL 60191 • Tel: (708) 350-8200 • Fax: (708) 350-8212